

CSCC63

Hamiltonian cycle problem

Instance: $\langle G \rangle$, where G is a directed graph.

Question: Does G have a Hamiltonian cycle?

Hamiltonian cycle: Visits every node exactly once.

Prove:

Vertex Cover \leq_m^p Directed Hamiltonian Cycle

Given $\langle G, k \rangle$ where G is an undirected graph and $k \in \mathbb{Z}^+$, construct a directed graph G_D s.t.

G has a vertex cover of size k

$\iff G_D$ has a directed Hamiltonian cycle

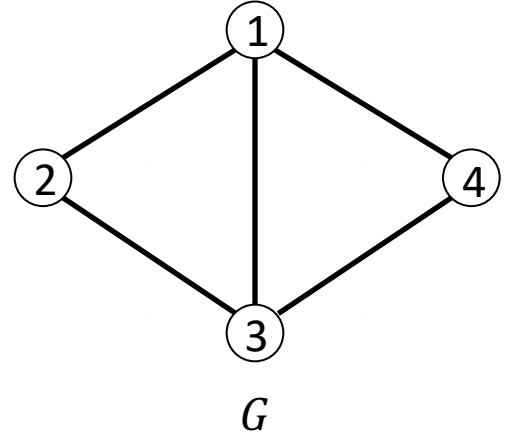

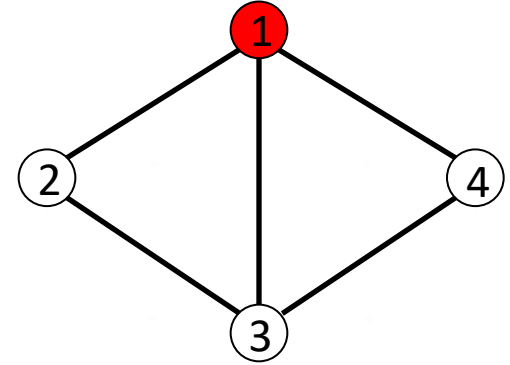
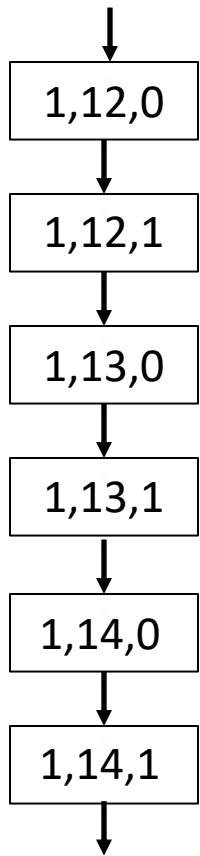

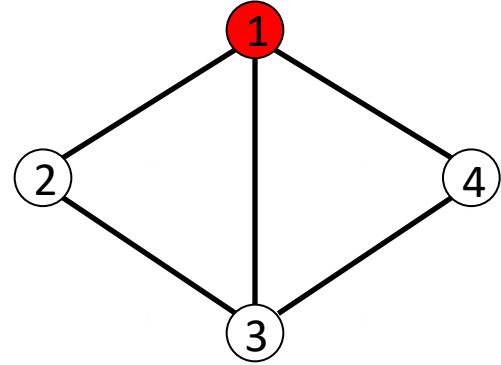
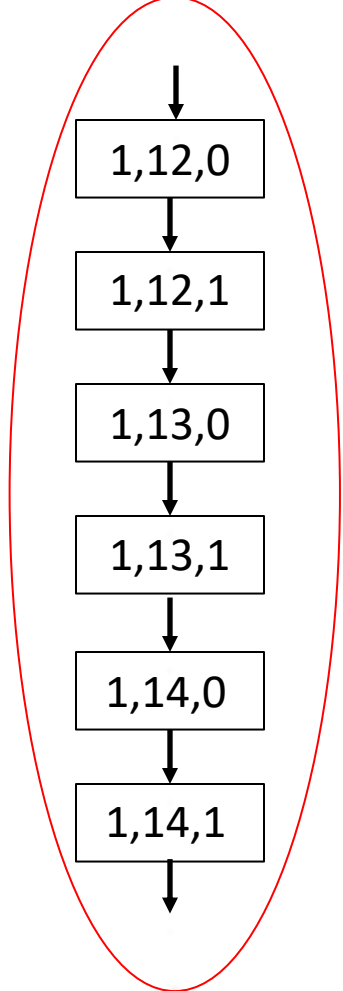

nodes of G_D
corresponding
to node 1 of G

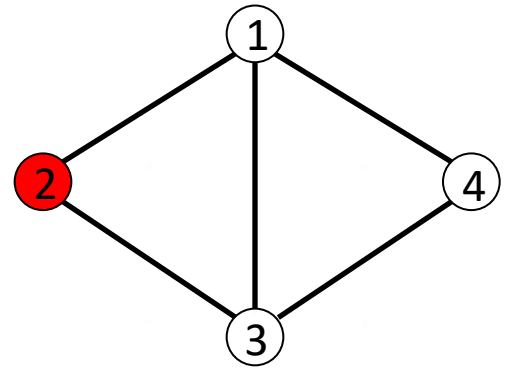
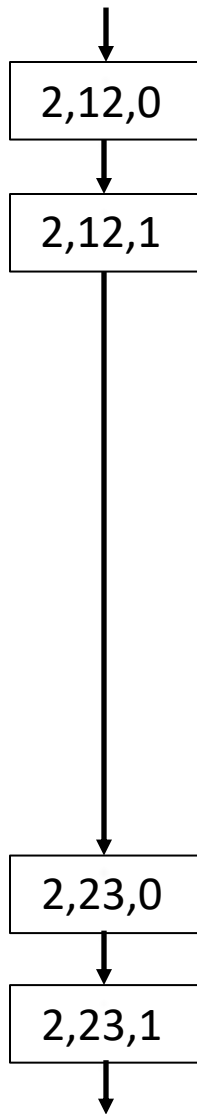
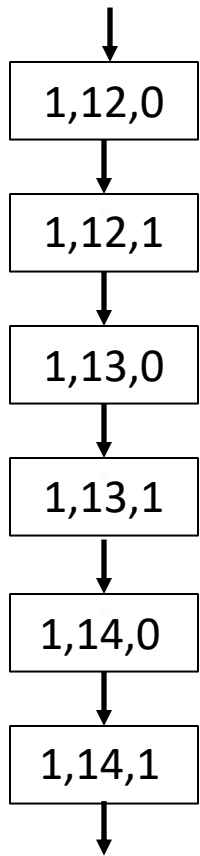

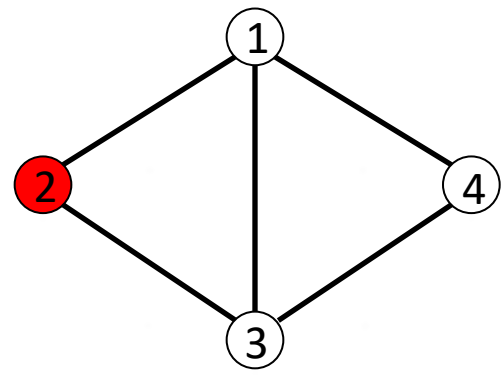
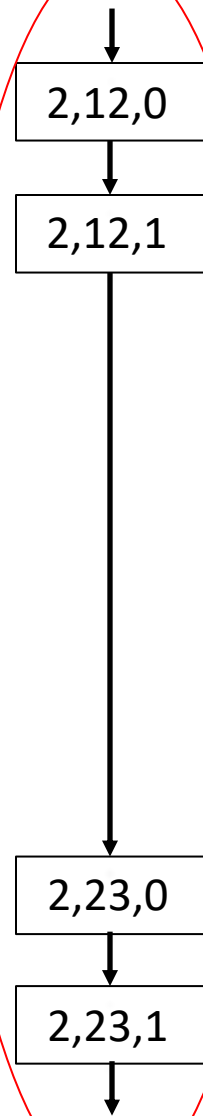
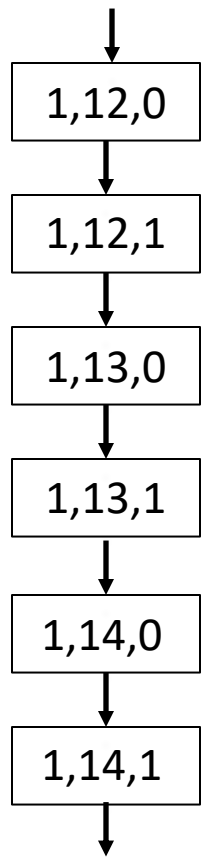

nodes of G_D
corresponding
to node 2 of G

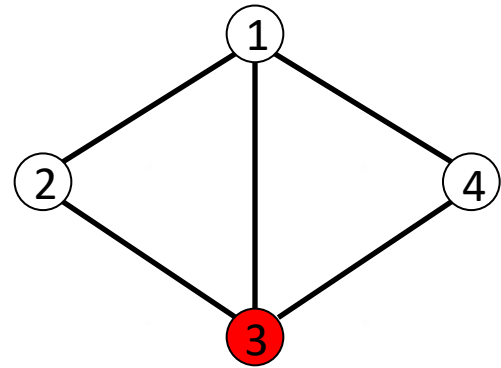
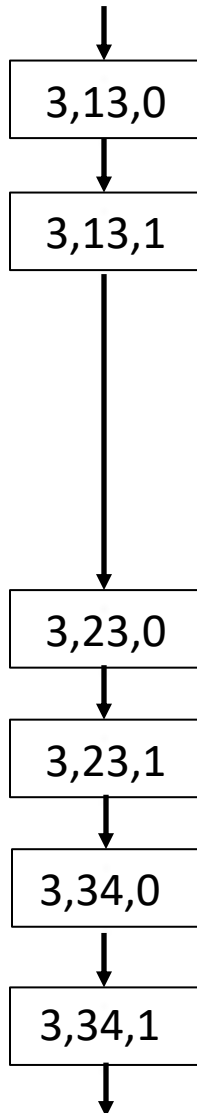
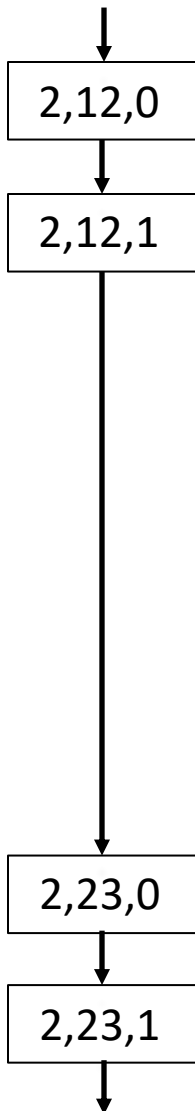
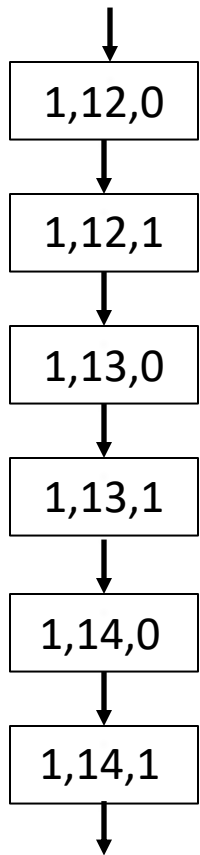

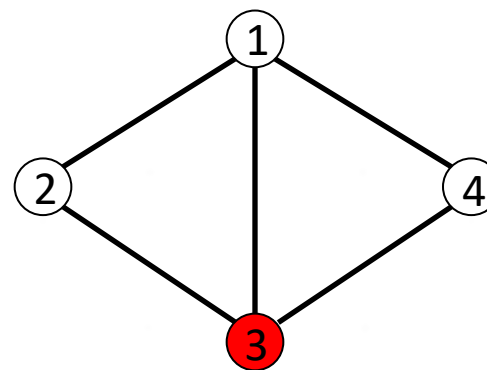
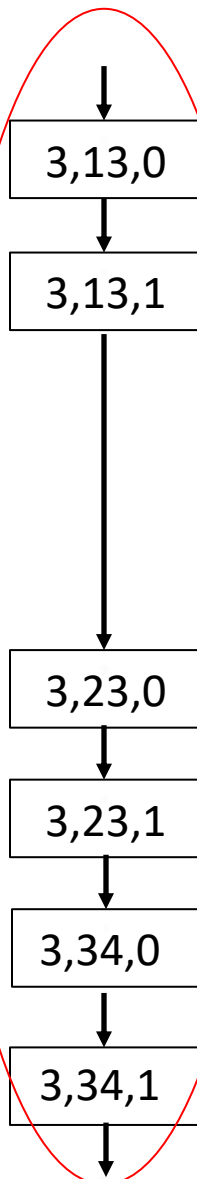
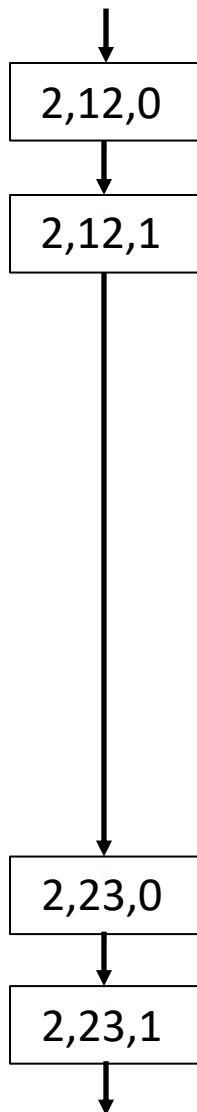
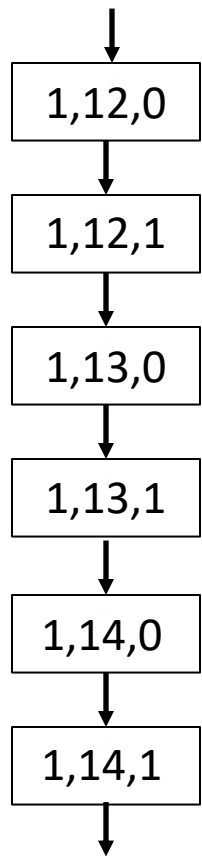

nodes of G_D
corresponding
to node 3 of G

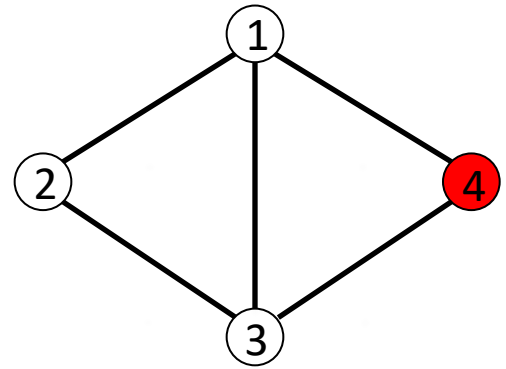
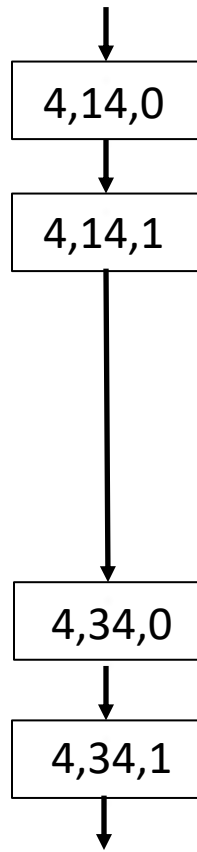
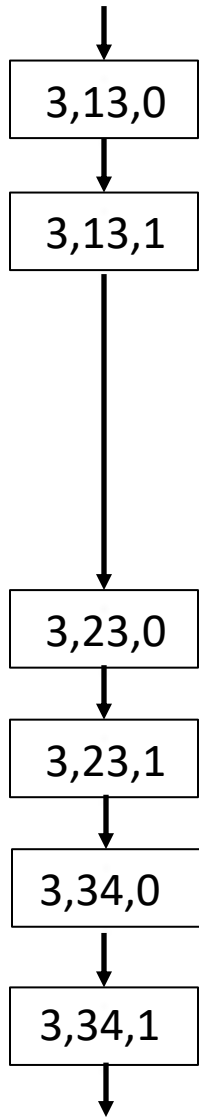
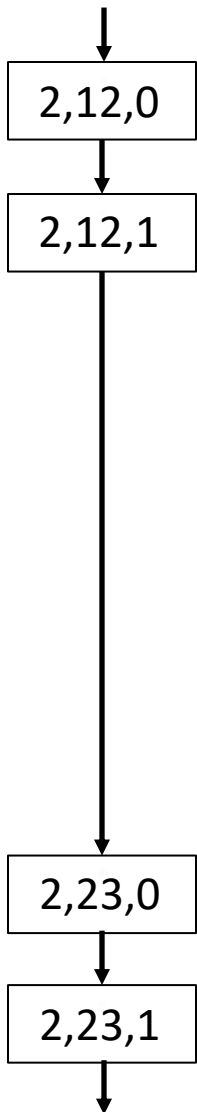
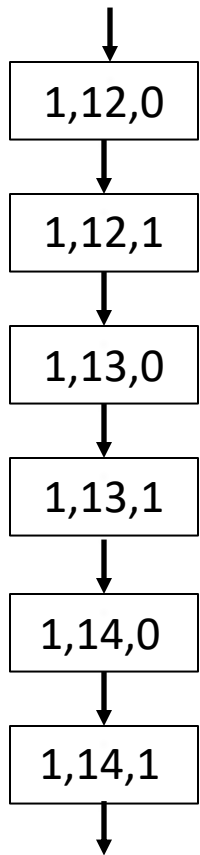

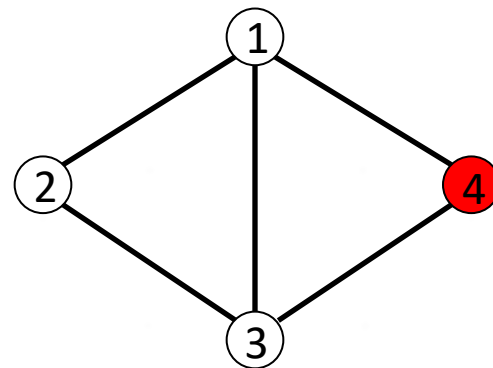
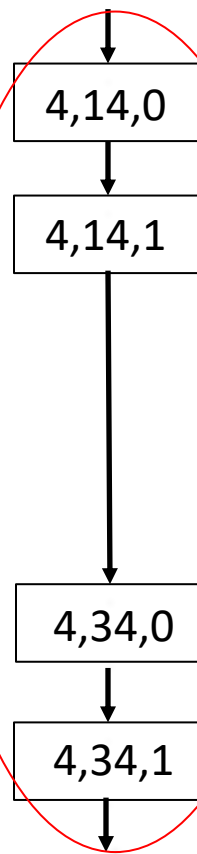
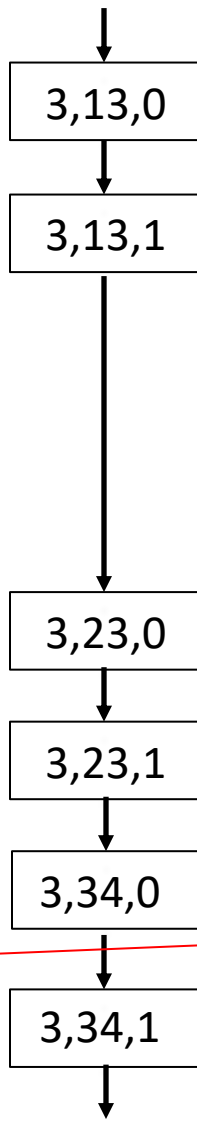
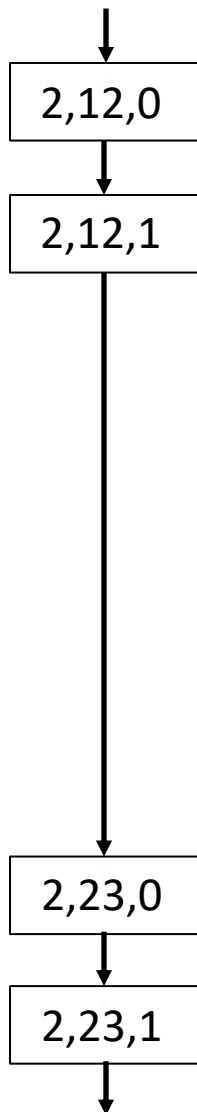
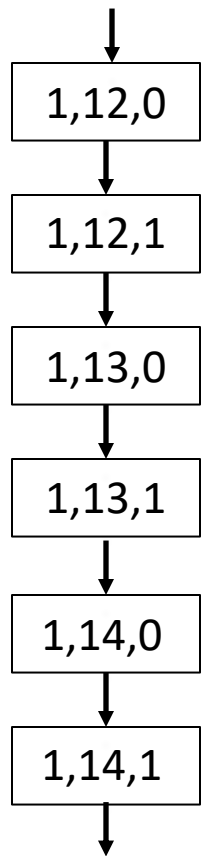

nodes of G_D
corresponding
to node 4 of G

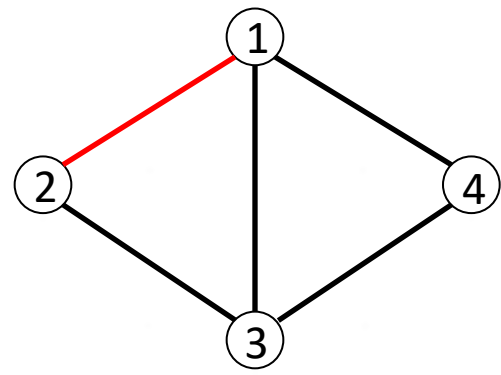
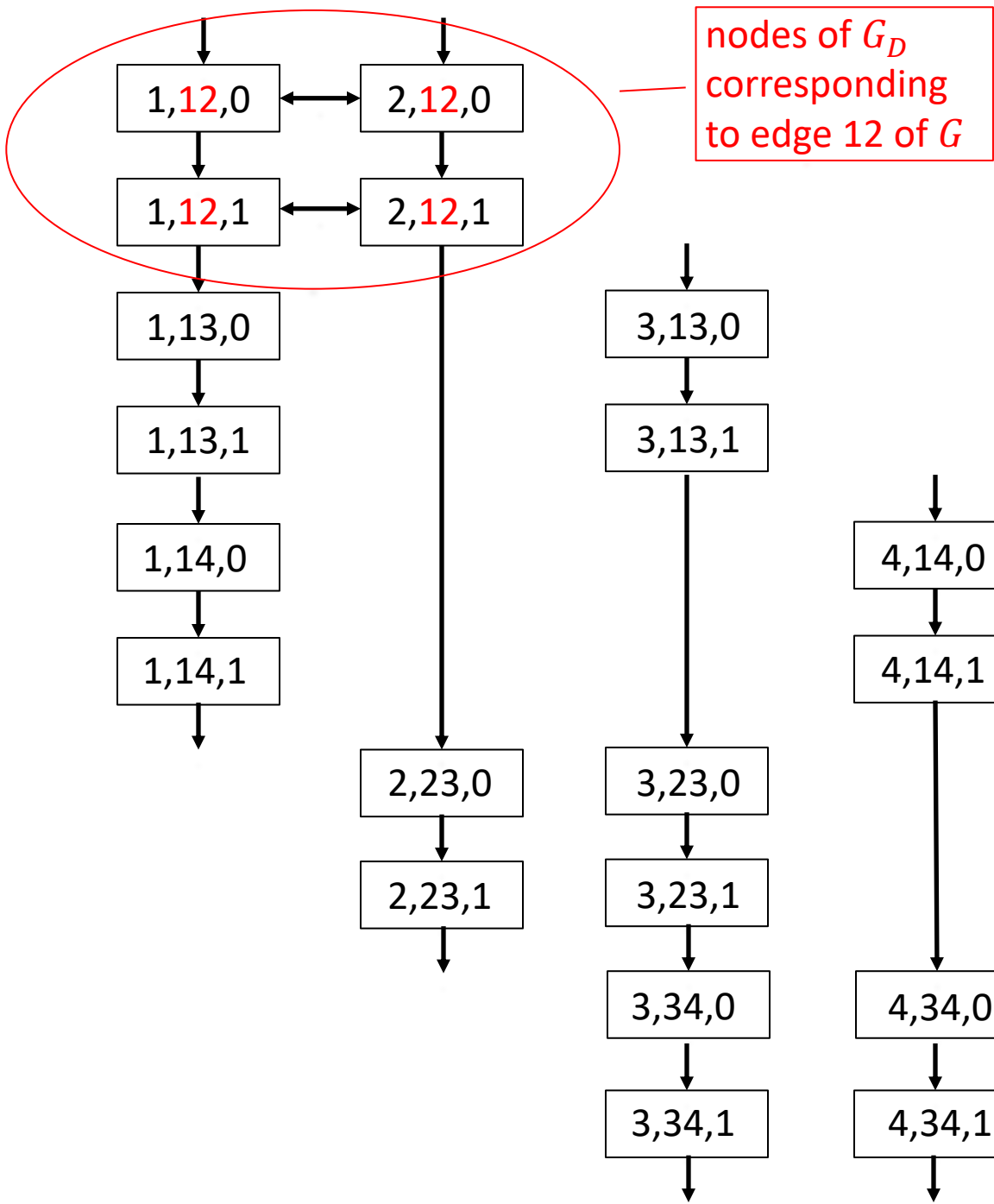

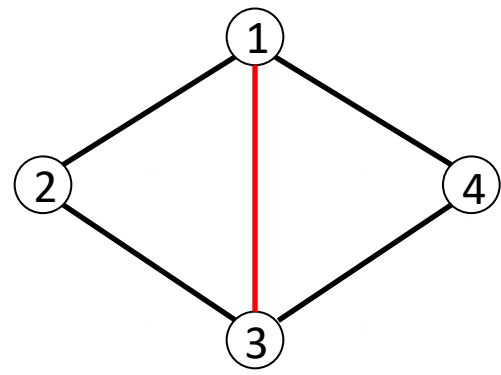
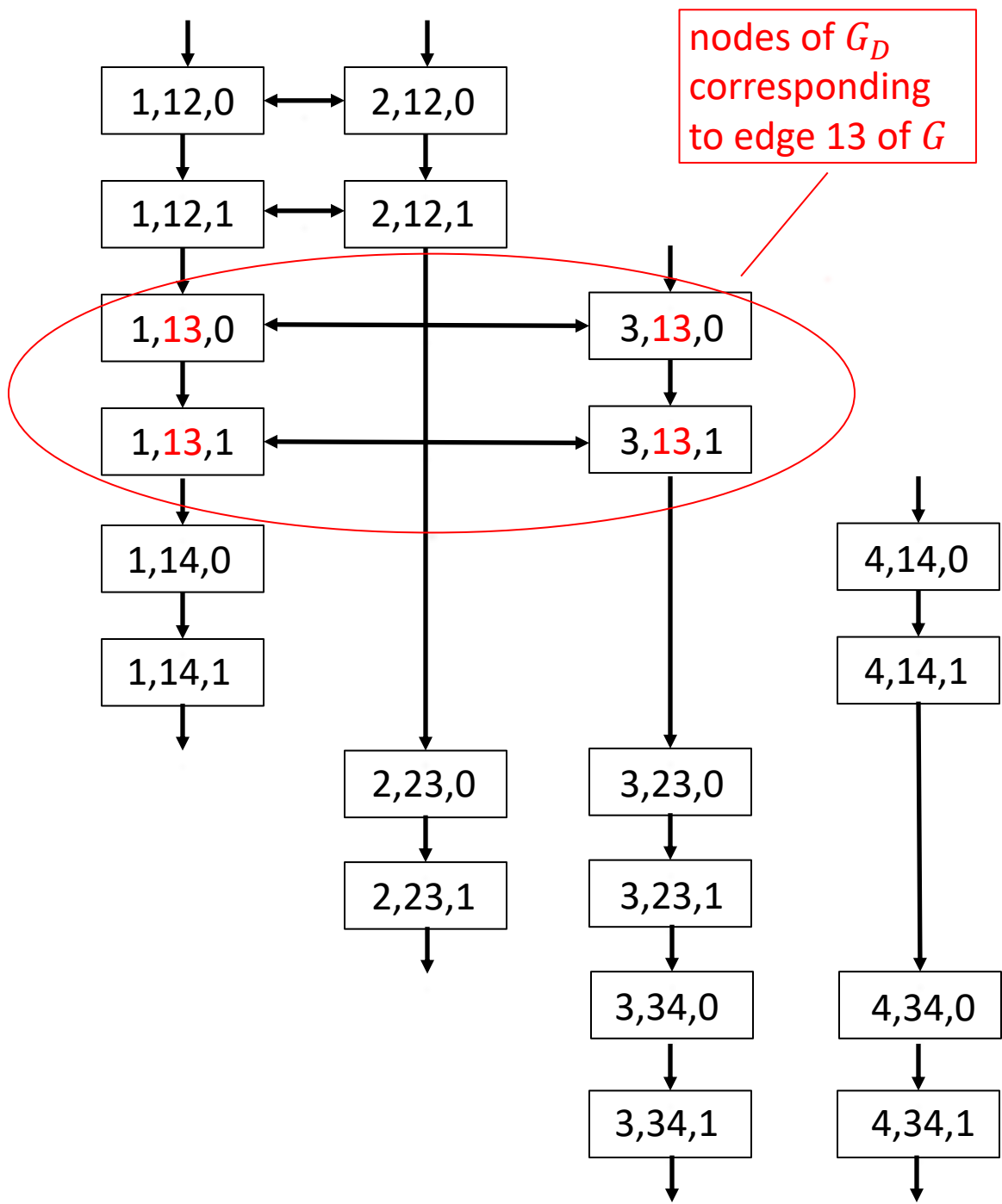

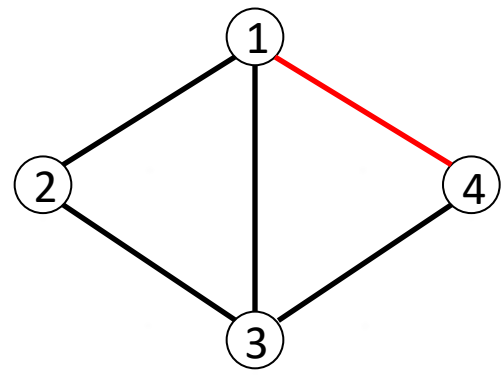
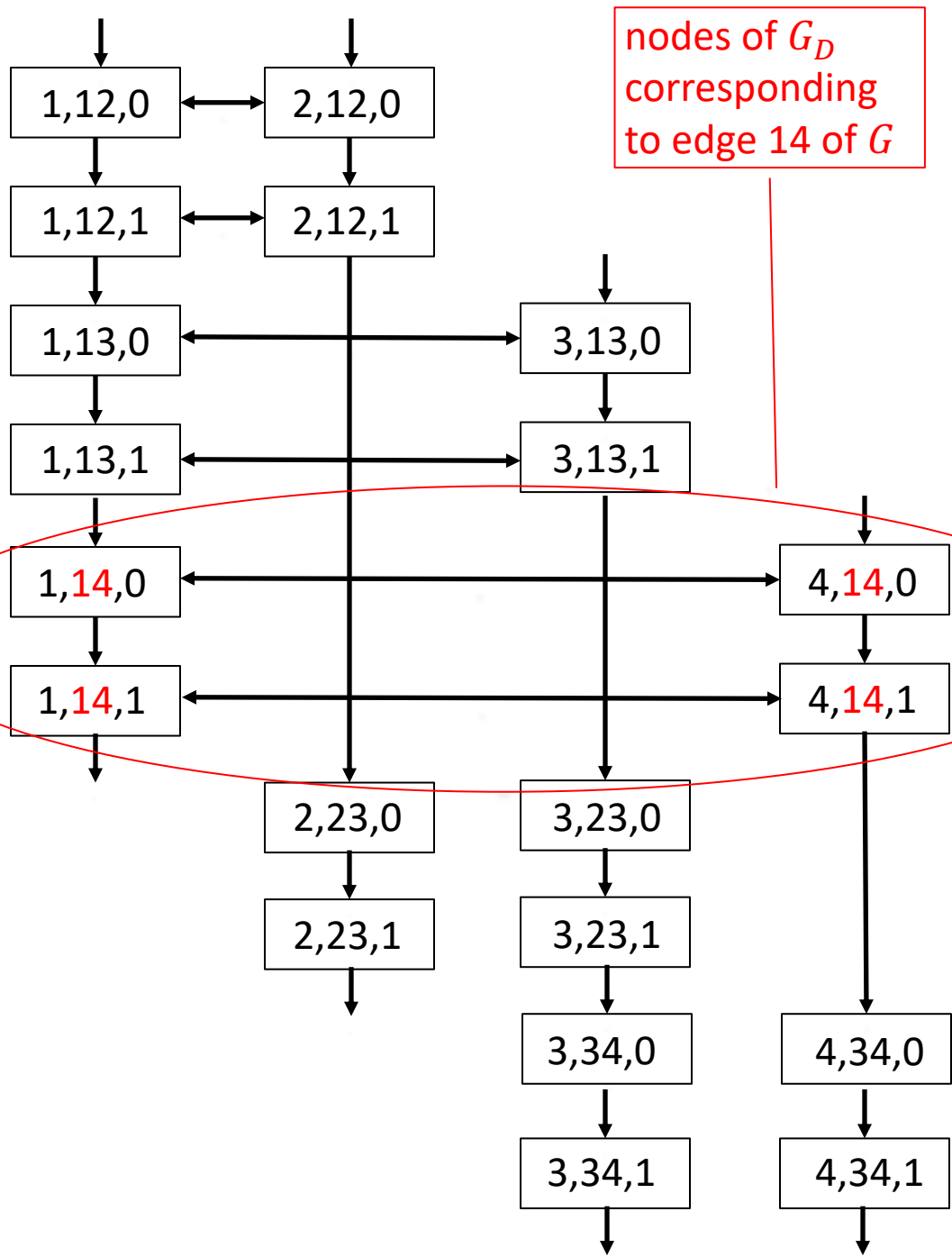

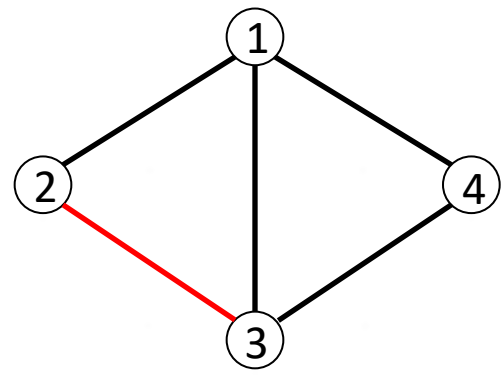
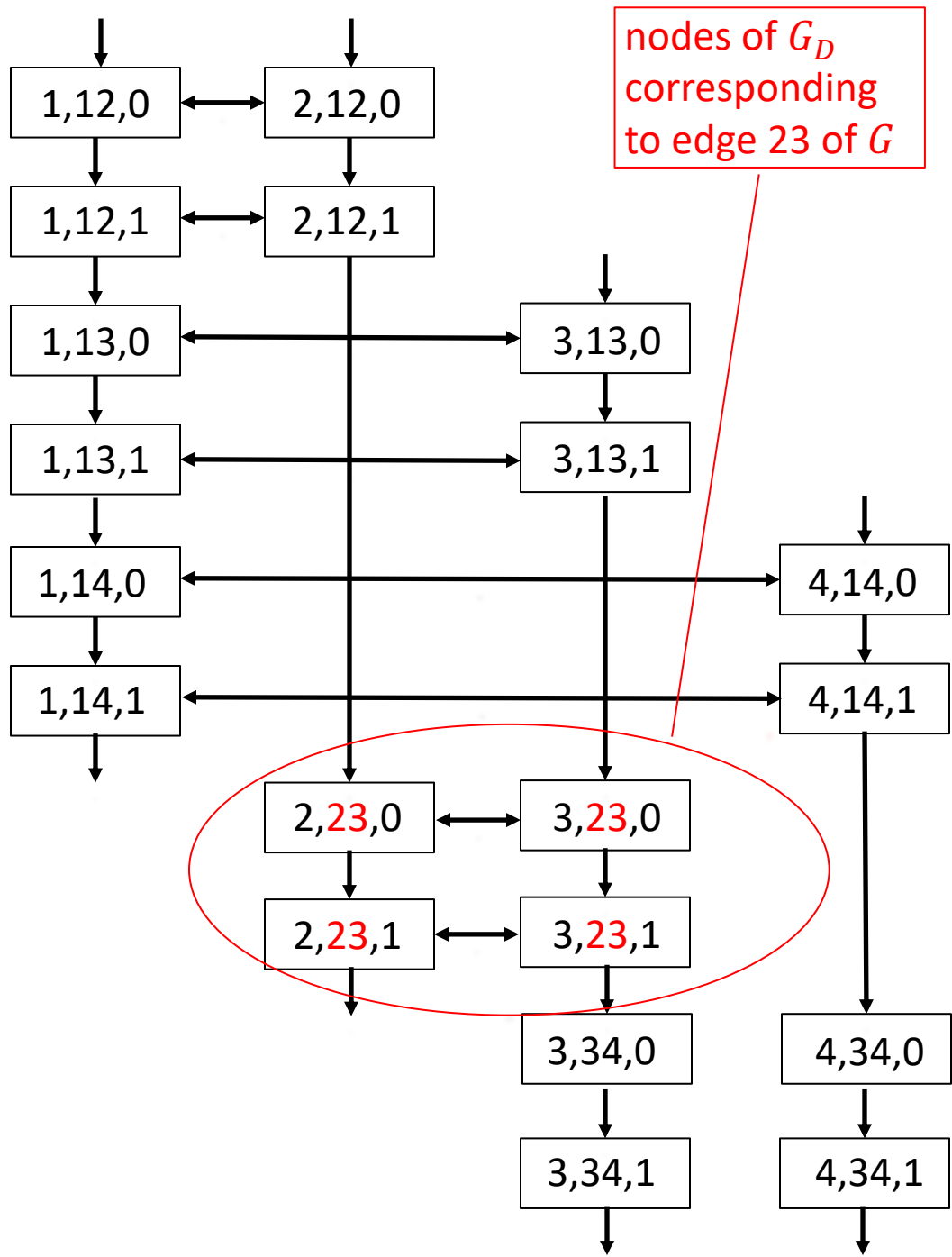

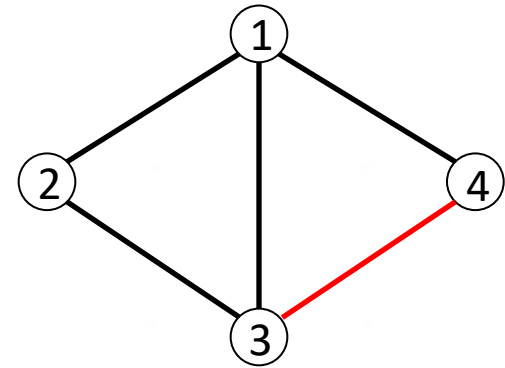
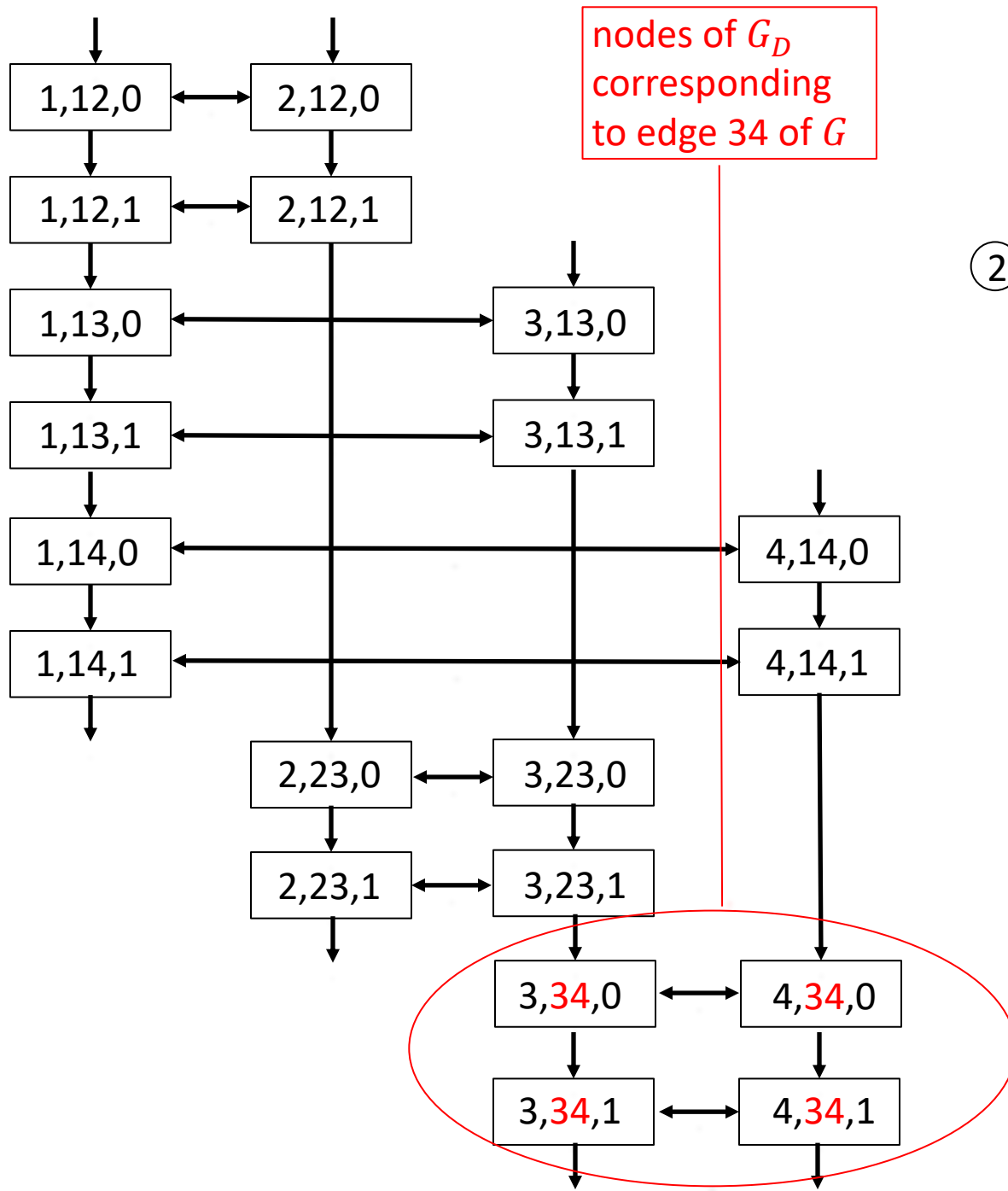

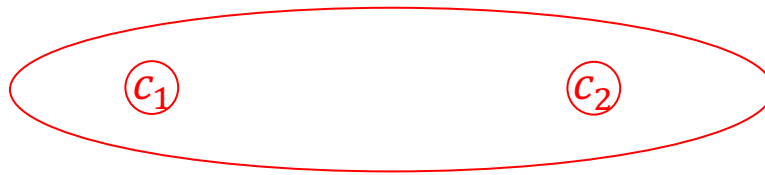

nodes of G_D
corresponding to
potential vertex
cover of size 2

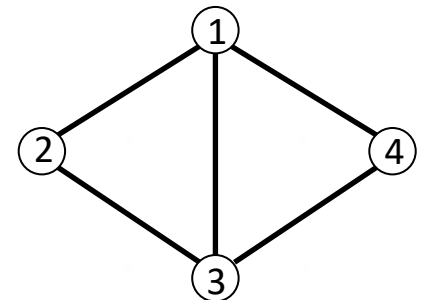
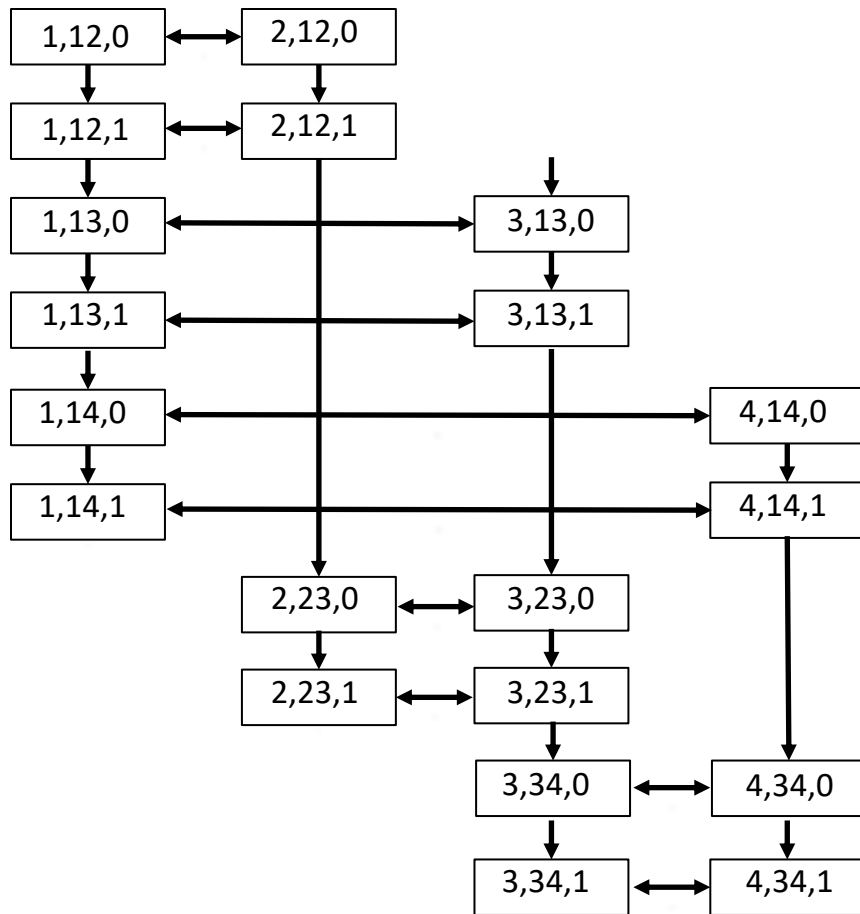

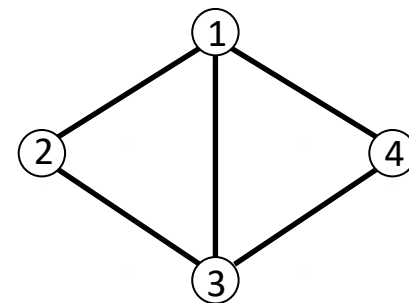
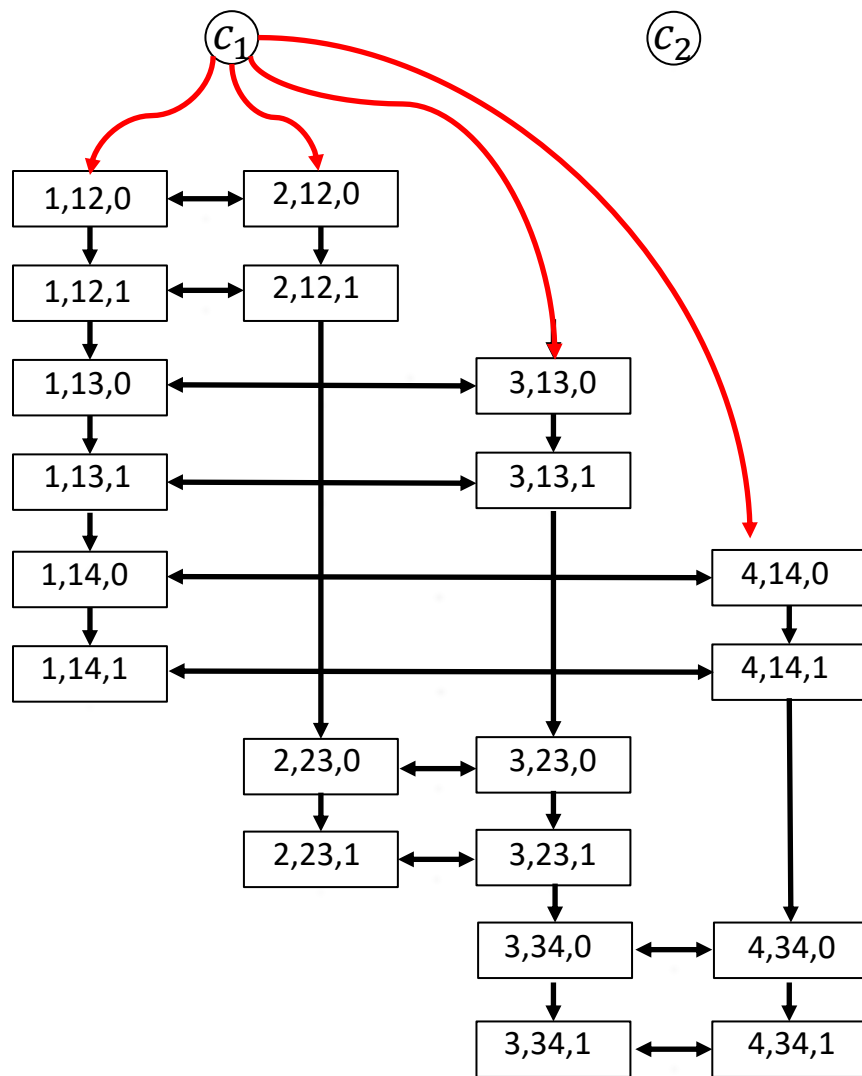

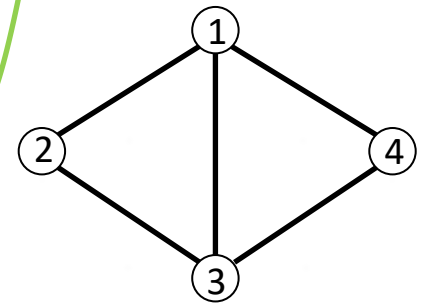
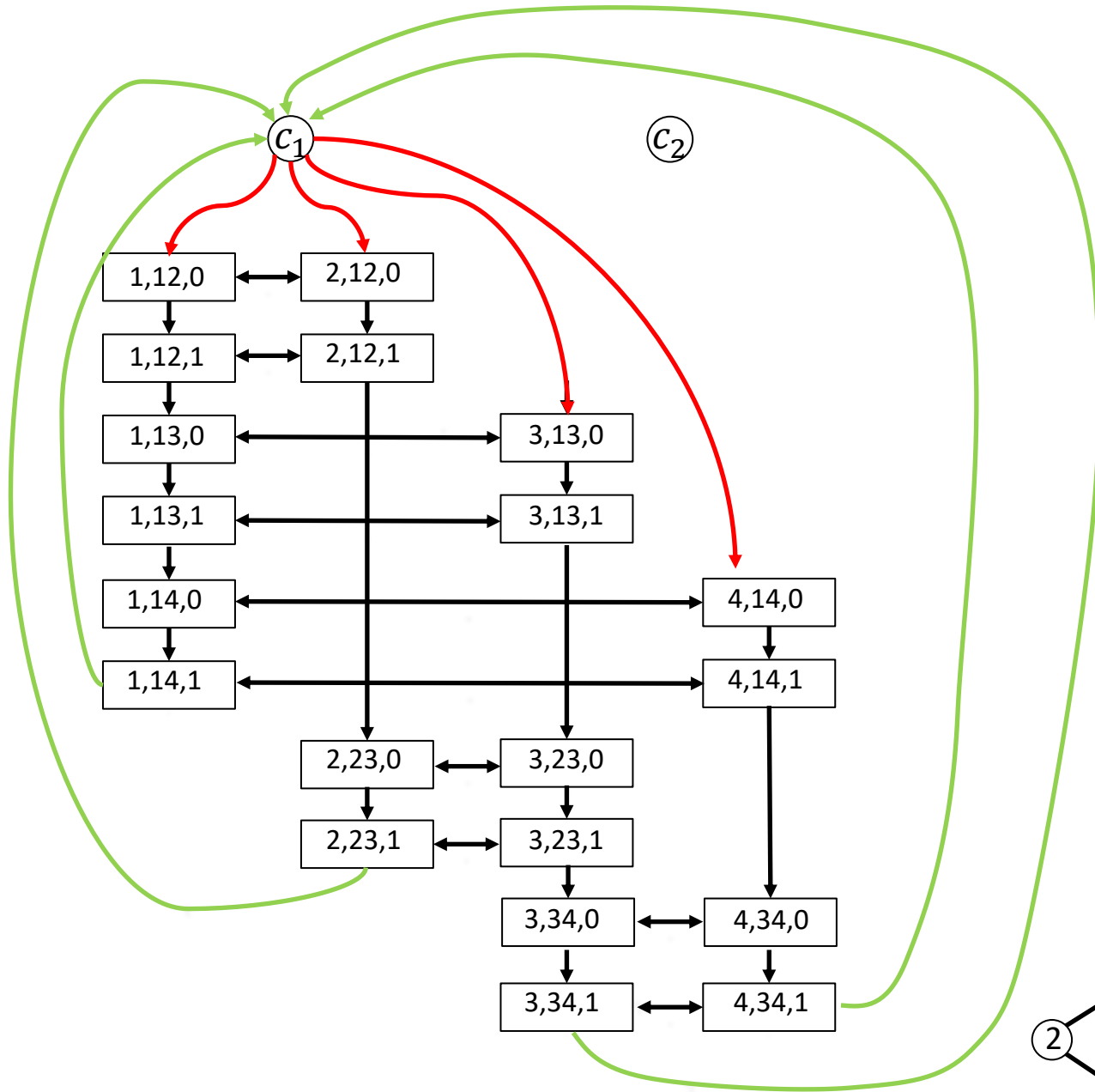

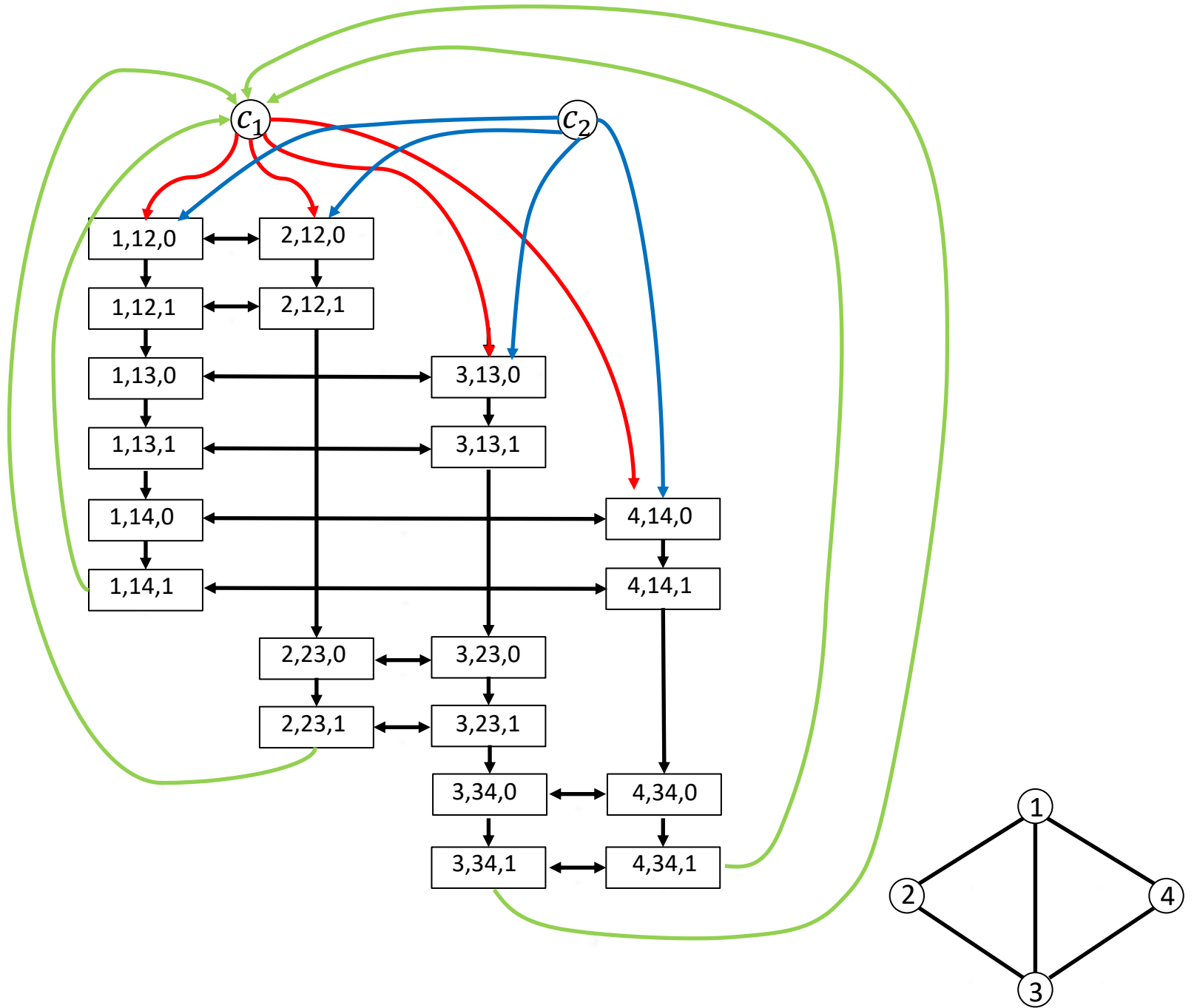

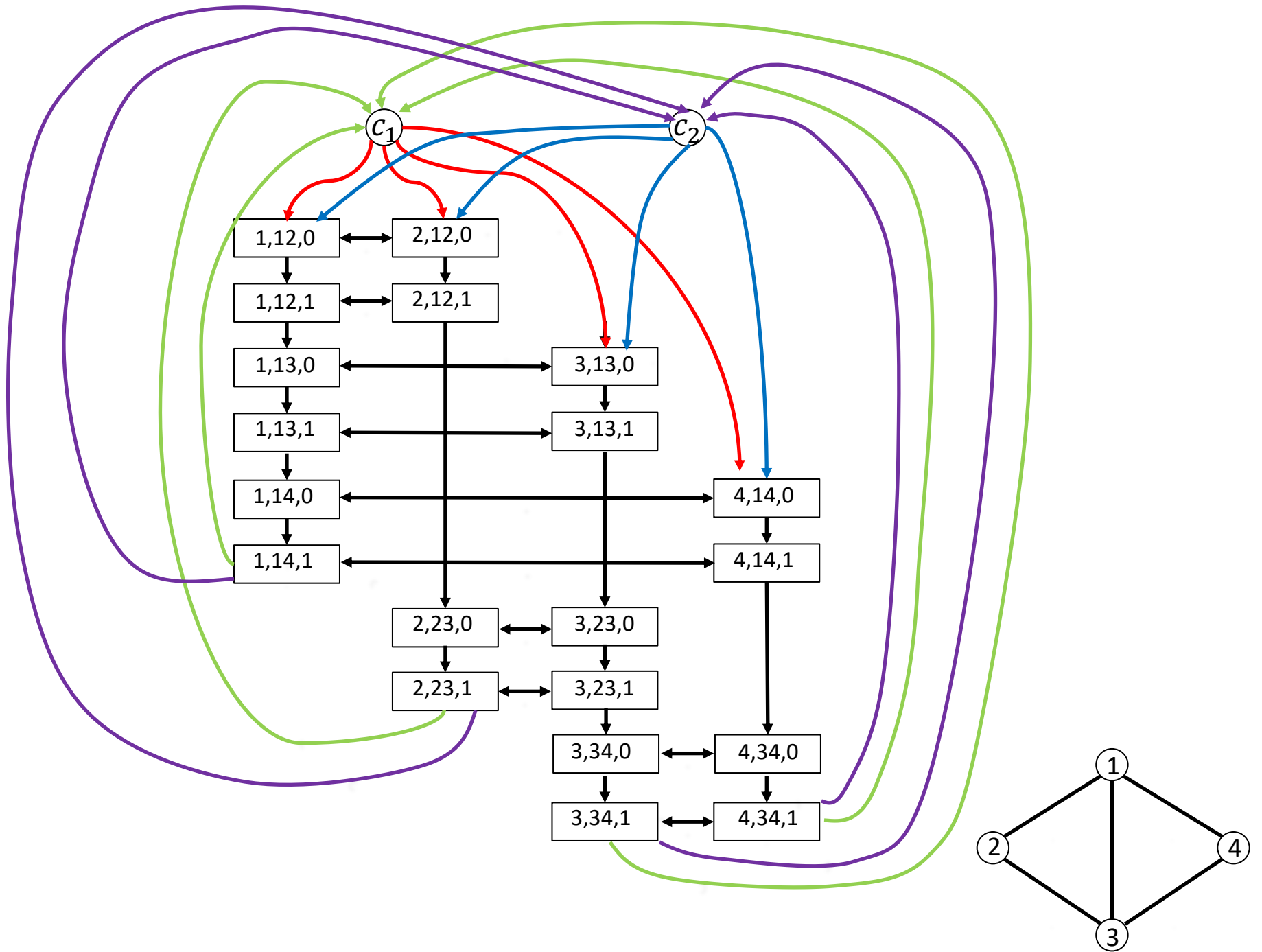

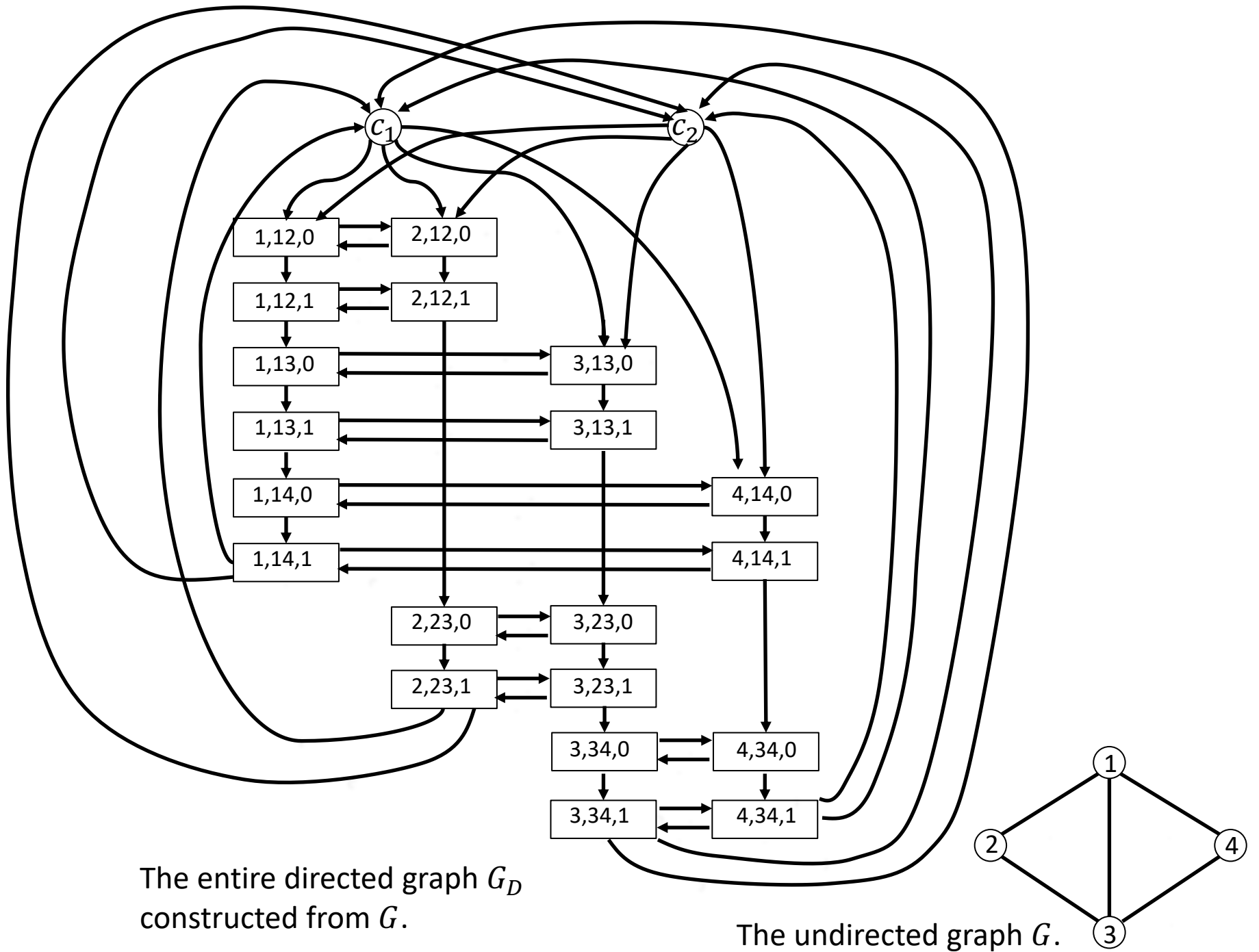

The entire directed graph G_D constructed from G .

The undirected graph G .

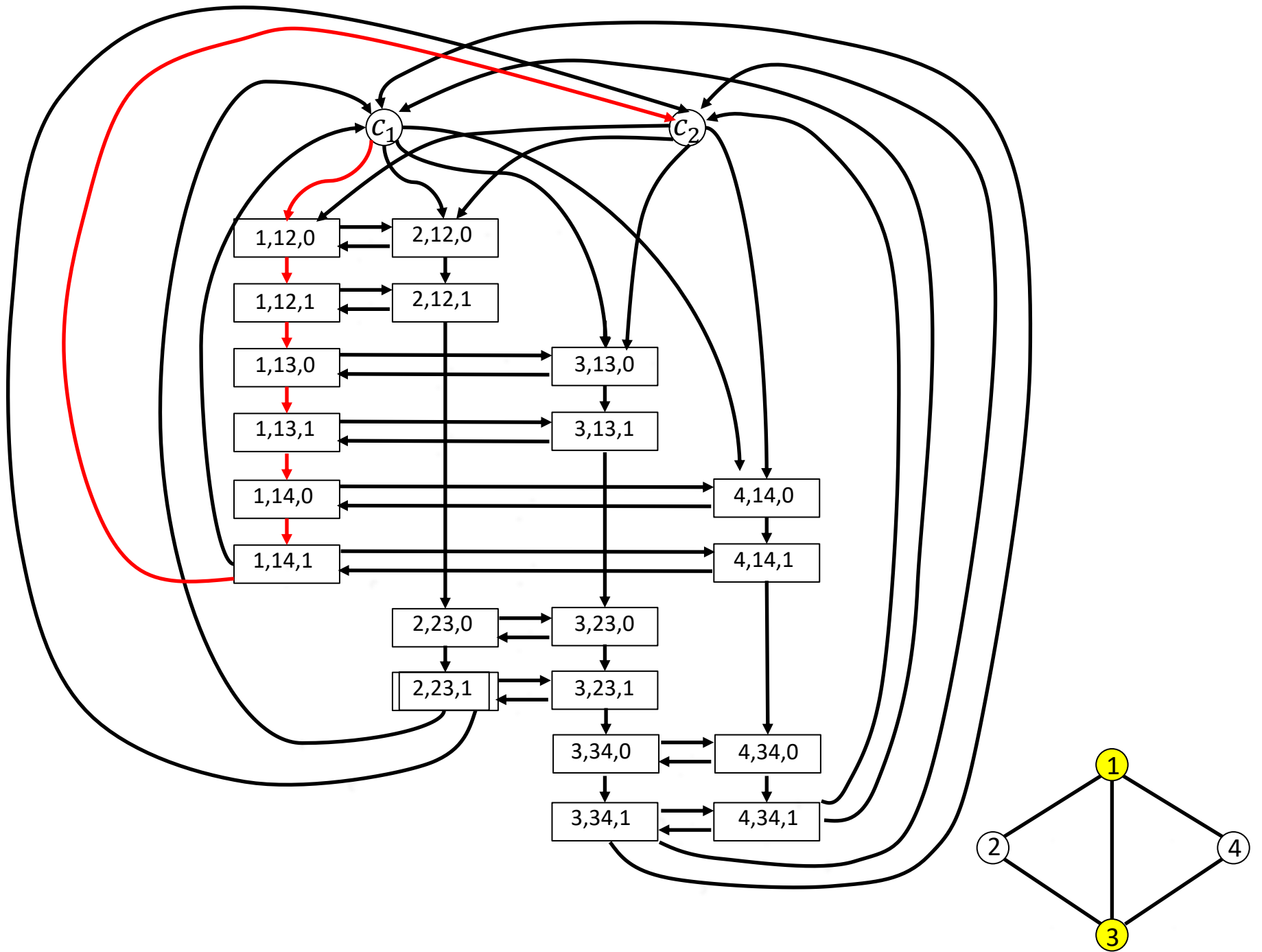

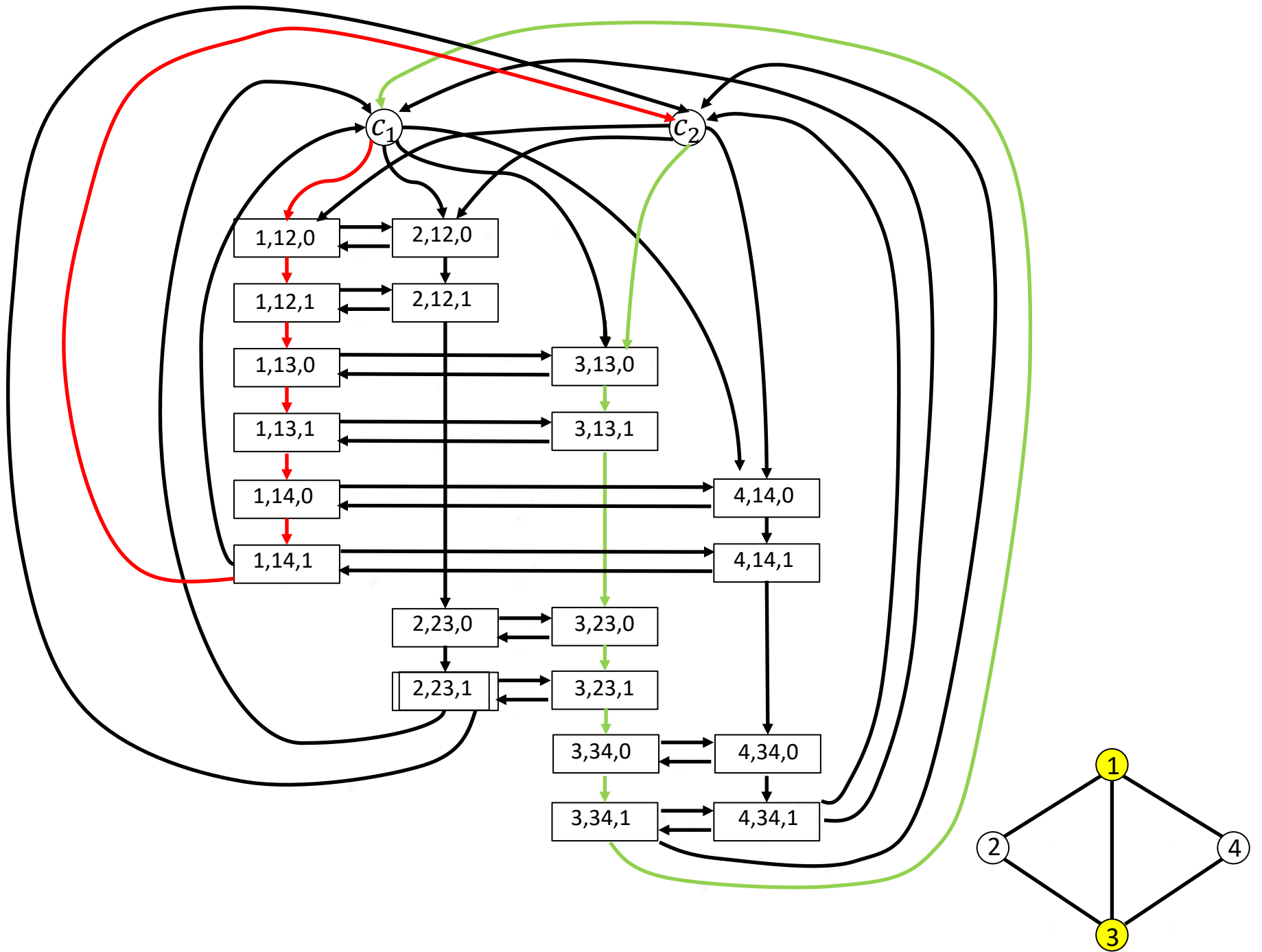

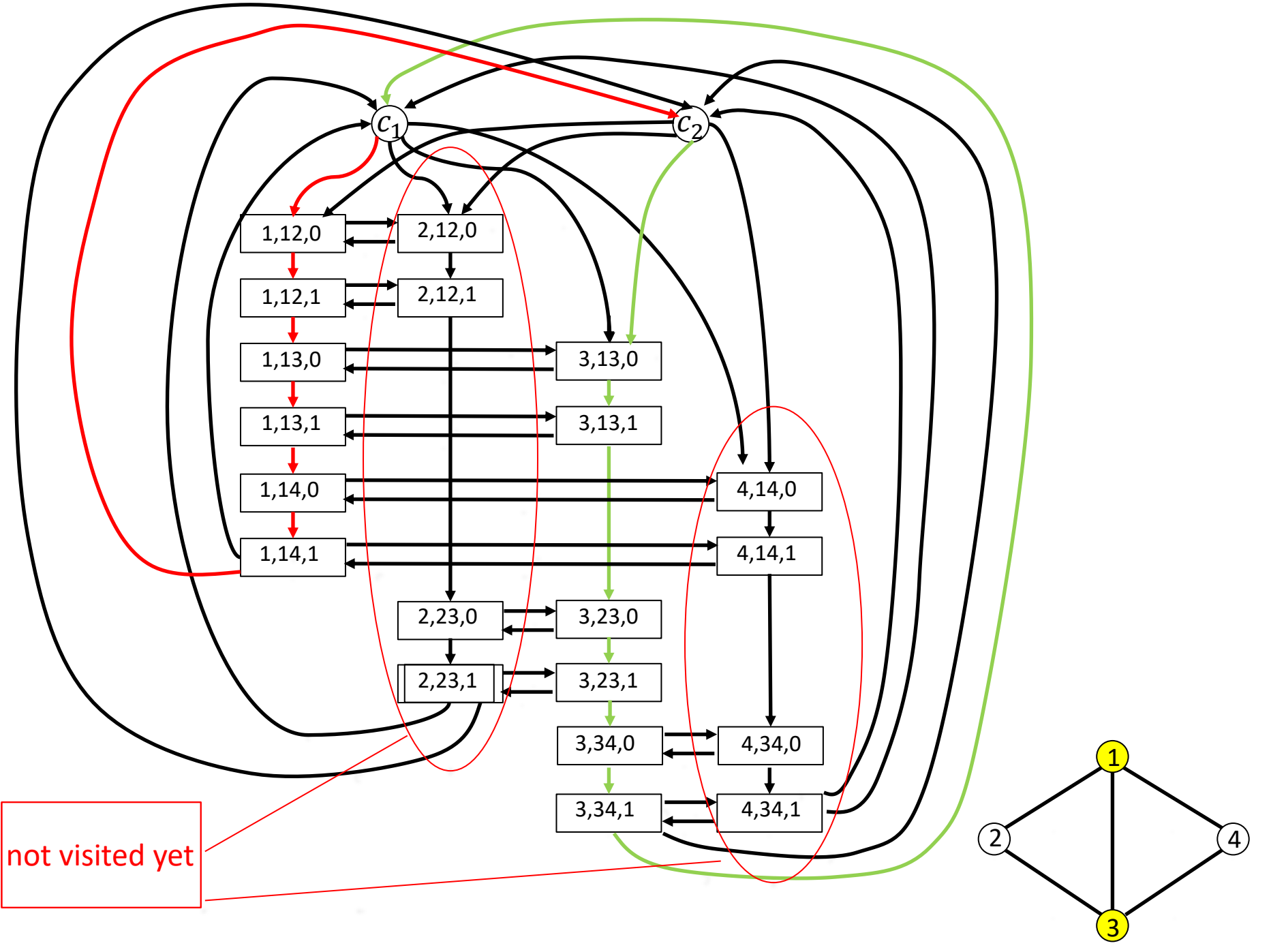

not visited yet

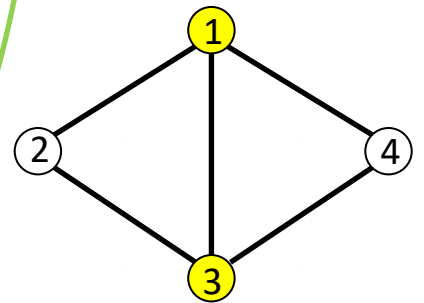

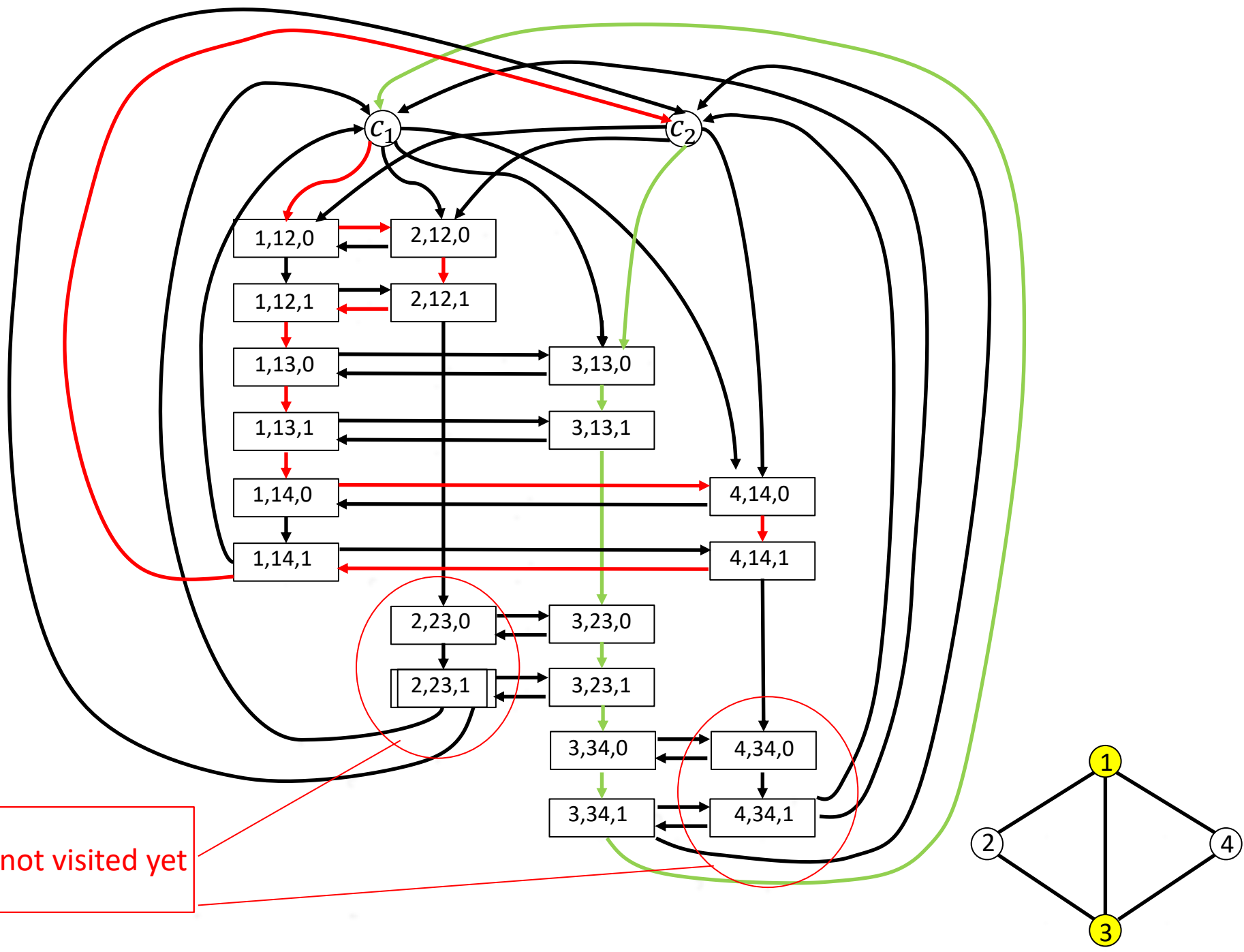

not visited yet

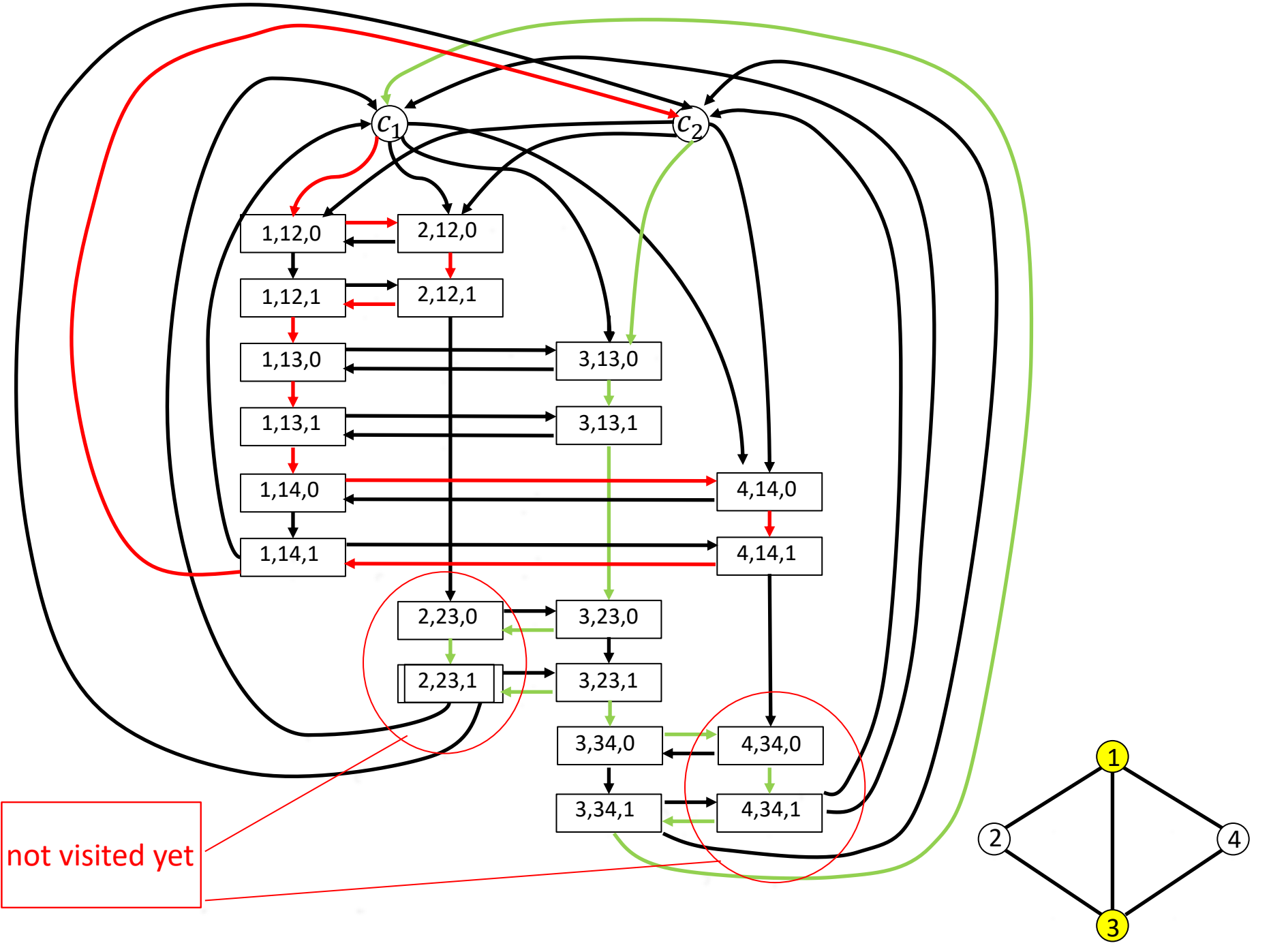

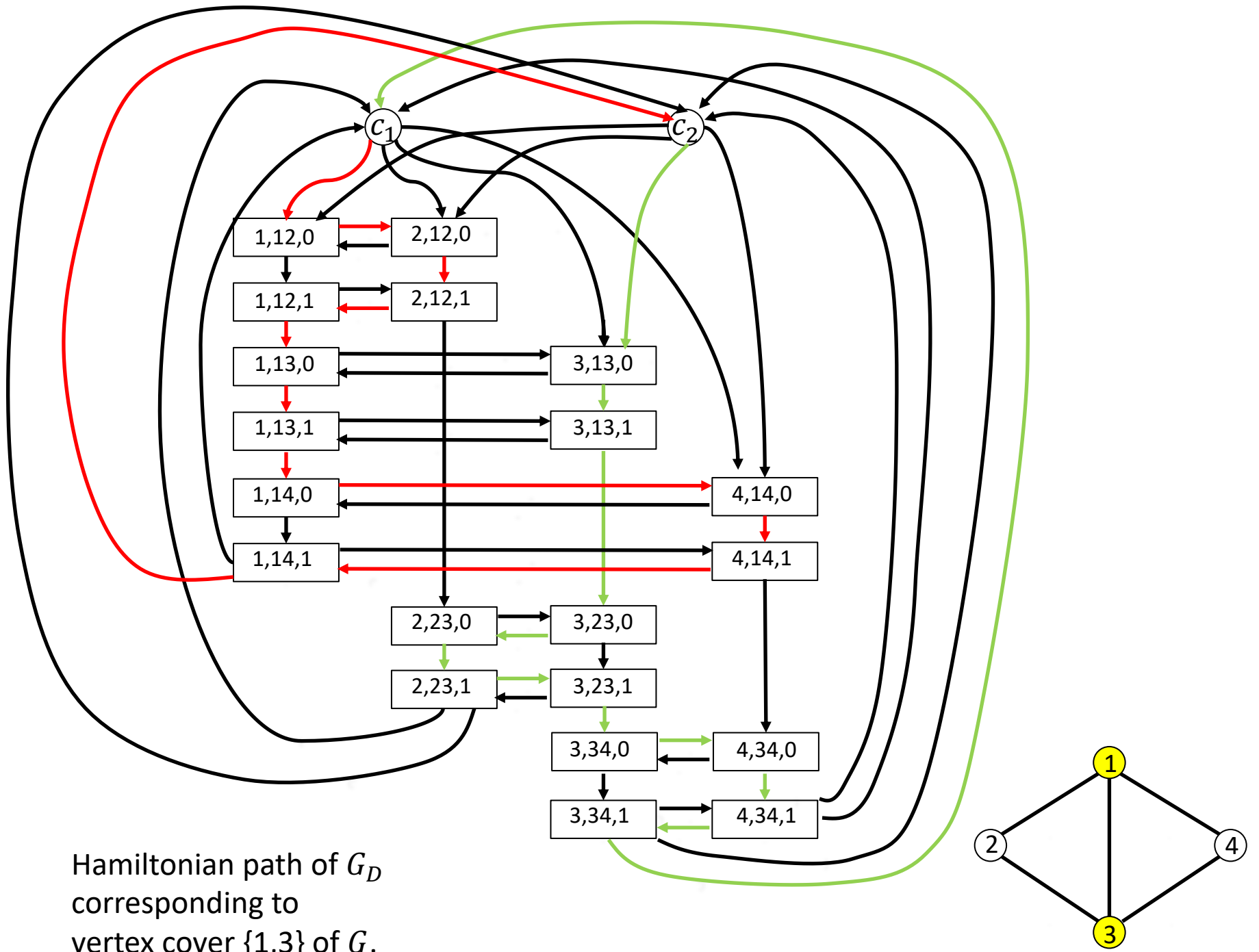

Hamiltonian path of G_D
 corresponding to
 vertex cover $\{1,3\}$ of G .