

Reduced clique graphs of chordal graphs[☆]

Michel Habib^a, Juraj Stacho^{b,1,2,3}

^aLIAFA-CNRS and Université Paris Diderot-Paris VII, Case 7014, 75205 Paris Cedex 13, France

^bWilfrid Laurier University, Department of Physics & Computer Science, 75 University Ave W, Waterloo, ON N2L 3C5, Canada

Abstract

We investigate the properties of chordal graphs that follow from the well-known fact that chordal graphs admit tree representations. In particular, we study the structure of reduced clique graphs which are graphs that canonically capture all tree representations of chordal graphs. We propose a novel decomposition of reduced clique graphs based on two operations: edge contraction and removal of the edges of a split. Based on this decomposition, we characterize asteroidal sets in chordal graphs, and discuss chordal graphs that admit a tree representation with small number of leaves.

Key words: chordal graph, clique tree, reduced clique graph, spanning tree, leafage, asteroidal triple, asteroidal number, split-minor, forbidden subgraph characterization

AMS classification: 05C15, 05C75

1. Introduction

A *tree representation* of a graph G consists of a host tree and a collection of its subtrees where the subtrees correspond to the vertices of G and two subtrees share a common vertex if and only if the corresponding vertices are adjacent. A *clique tree* of G is a tree representation of G in which the nodes of the host tree “correspond” to the maximal cliques of G , i.e., for each node of the host tree, the set of vertices of G whose corresponding subtrees contain that particular node is a maximal clique of G . Equivalently, we can define a clique tree of G as a tree whose vertices are the maximal cliques of G and who satisfies a particular condition (see Section 1.1). It can be readily seen that from every tree representation of G , by (possibly) contracting some edges of the host tree, one can always obtain a clique tree of G .

A graph is *chordal* if it contains no induced cycle of length four or more. It is well-known that chordal graphs are precisely the graphs that admit tree representations [2, 6], or equivalently, the graphs that admit clique trees. In this paper, we focus on this aspect of chordal graphs, and study properties of chordal graphs associated with the structure of clique trees. In particular, we investigate the recently rediscovered notion of the *reduced clique graph* of a chordal graph. This is the graph we obtain by taking the maximal cliques of a chordal graph G as vertices, and by putting edges between those vertices for which the corresponding cliques intersect in a minimal separator that separates them (see Section 2 for a precise definition). This is a subgraph of the (usual) *clique graph* of G (where edges are between cliques that intersect) and was first defined in [5] more than fifteen years ago. Since then, this notion was largely ignored (likely due to the fact that it was named “clique graph”

[☆]The conference version of this paper appeared as [10].

Email addresses: habib@liafa.jussieu.fr (Michel Habib), stacho@cs.toronto.edu (Juraj Stacho)

¹Author initially supported by Fondation Sciences Mathématiques de Paris.

²Author further supported by Kathie Cameron and Chinh Hoàng via their respective NSERC grants.

³*Present address:* University of Warwick, Mathematics Institute, Zeeman Building, Coventry, CV4 7AL, United Kingdom

in [5] where the (more usual) clique graph was called “clique intersection graph”), and only recently [9, 19, 20], there has been some interest in properties of this derived graph.

The aim of this paper is to further stimulate the interest in reduced clique graphs by describing some aspects of their structure, explaining where they differ from similar (established) notions, and in what way they can help us in solving computational problems. Our contribution consists of two parts.

Part 1. *Structure and decomposition of labeled reduced clique graphs*

Since at least the papers of Gavril [7] and Shibata [22], it has been known that the set of all clique trees of a chordal graph G is precisely the set of all maximum-weight spanning trees of the clique graph of G where the weight of an edge is defined as the size of the intersection of the corresponding cliques of G . As shown in [5] (also see Theorem 3 in Section 2), this is also true for the reduced clique graph of G but, unlike the (usual) clique graph, the reduced clique graph of G has the additional property that each of its edges appears in at least one clique tree of G . (In other words, the reduced clique graph G is the (unique) union of all clique trees of G .) At first glance, this might not seem like a big advantage, but there are examples [11, 19, 20] where it helps to deal with the reduced clique graph of G rather than with its (usual) clique graph. To illustrate one of the fundamental differences between the two clique graphs, note that adding a universal vertex to a connected chordal graph G turns its clique graph into a complete graph whereas its reduced clique graph remains unchanged.

In the first part of this paper (in Section 2 and 3), we first describe the general structure of reduced clique graphs based on minimal separators. Then we propose a particular decomposition of reduced clique graphs using the following two operations: the contraction of an edge, and the removal of the edges of a split. For these two operations, we shall only consider particular edges and splits (as explained later), and call any graph obtained using a combination of the two operations a *split-minor*. It turns out, as we show, that these operations, when performed on the reduced clique graph of a chordal graph G , correspond directly to operations on G . In other words, we show that every split-minor of a reduced clique graph is again a reduced clique graph. Moreover, we show that in every reduced clique graph there is at least one edge and at least one split that we can contract or remove, respectively. This, in particular, will imply these two operations allow removing all edges of every reduced clique graph in some order which is also true for each of its split-minors (i.e., any valid sequence of these two operations can be extended to one that removes all edges). We feature this decomposition mainly in the second part of this paper, but we envision that it may find algorithmic uses in inductive constructions of solutions for problems on reduced clique graphs from solutions on their split-minors.

Part 2. *Use of reduced clique graphs to characterize properties of chordal graphs*

In the second part of the paper (in Section 4 and 5), we focus on parameters of chordal graphs, in particular, those that can be described in terms of their reduced clique graphs. First, we focus on the notion of an asteroidal set and an asteroidal number. We say that a set of vertices A of a graph G is *asteroidal* if for each $a \in A$, the vertices in $A \setminus \{a\}$ belong to a common connected component of $G - N[a]$; the *asteroidal number* of G , denoted by $a(G)$, is then the size of a largest asteroidal set of G .

We start by showing that asteroidal sets (of vertices) in chordal graphs correspond to *asteroidal collections of (maximal) cliques* (see Section 4). This will allow to look at these sets purely from the perspective of reduced clique graphs and thus will allow us to apply the notion of a split-minor. In particular, we show that the asteroidal number of a graph is a monotone parameter with respect to a particular (but rather technical) restriction of the notion of a split-minor that we call a *good split-minor* (explained later). That is, we show that if the reduced clique graph of G is a good split-minor of the reduced clique graph of G' , then $a(G) \leq a(G')$. Note that this will allow us to conclude that there exists a collection of reduced clique graphs such that a chordal graph G satisfies $a(G) < k$ if and only if the reduced clique graph of G contains no good split-minor from the collection. We then go on to prove that such a collection consists precisely of one graph (up to the labels of edges), namely, the star with k edges. In the case $k = 3$, this will provide us with a new characterization of *interval graphs* using a single forbidden obstruction. (Recall that interval graphs are the intersection graphs of intervals of

the real line, or equivalently, the chordal graphs with $\alpha(G) < 3$ as shown in [16]). We remark that this is different from other known characterizations of interval graphs such as the characterization by forbidden induced subgraphs which contains several infinite families (see Figure 6).

Secondly, we look at another parameter of chordal graphs G , the *leafage* $l(G)$, which is defined as the smallest number of leaves in the host tree of a tree representation of G , or equivalently, the smallest number of leaves in a clique tree of G . We similarly apply the notion of a split-minor to this concept. We show that the leafage is also monotone but for a different restriction of the notion of a split-minor, and we further discuss small substructures that cause the leafage to be large.

We remark that it is known that both the asteroidal number and the leafage can be computed in polynomial time for chordal graphs by the respective algorithms from [13] and [11]. But it is the results presented in this paper that provide us with a structural understanding that underpins the two algorithms. In particular, the algorithm in [11] is largely based on the work from this paper, whereas the algorithm from [13] can be, in fact, seen as trying to find a labeled k -star when deciding if the given graph has asteroidal number at least k .

The interest in these two parameters is mainly due to the fact that if they are bounded, we can efficiently solve several problems on chordal graphs that would otherwise be hard. For instance, the maximum independent dominating set [1] and branchwidth [21] can be solved efficiently if the asteroidal number, respectively, leafage is bounded. Also, bandwidth [14] can be efficiently $2k$ -approximated on chordal graphs of leafage at most k . We note that these and similar results largely stem from the observation that the two parameters can be seen as a measure of how far a chordal graph is from being an interval graph as the leafage and asteroidal number two correspond precisely to interval graphs. When one of the parameters is bounded, one can usually adapt an efficient algorithm that works for interval graphs to also work on chordal graphs where the parameter is bounded.

Finally, note that, as this is a structural paper, we do not discuss complexity issues here such as the ones connected to testing for the existence of a (fixed) split-minor in a given graph. Further, we do not analyze the structure of unlabeled reduced clique graphs, that is, the structure of graphs that can be labeled to become reduced clique graphs. These issues are currently a subject of an ongoing investigation of the authors and will be published separately.

For notation and standard graph-theoretical notions used in this paper we refer the reader to [23].

1.1. Clique tree

A *clique tree* of a connected chordal graph G is any tree T whose vertices are the maximal cliques of G such that for every two maximal cliques C, C' , each clique on the path from C to C' in T contains $C \cap C'$. Further, the edges of T are labeled where edge CC' of T has label $C \cap C'$. (See Figure 1b)

1.2. Minimal separators

A set $S \subseteq V(G)$ *disconnects* a vertex a from b in G if every path of G between a and b contains a vertex from S . A non-empty set $S \subseteq V(G)$ is a *minimal separator* of G if there exist a and b such that

- (i) S disconnects a from b in G , and
- (ii) no proper subset of S disconnects a from b in G .

Observe that the definition implies that the vertices a, b are necessarily in the same connected component of G , since otherwise the empty set disconnects them and thus violates (ii).

For instance, the set $S = \{a, c\}$ is a minimal separator of the graph G in Figure 1a, since it disconnects b and d but neither $\{a\}$ nor $\{c\}$ does, because of the paths d, c, b and d, a, b , respectively. Similarly, $S = \{a\}$ is a minimal separator, because it disconnects g and c . This emphasizes that, unlike what its name suggests, a minimal separator is not necessarily an inclusion-wise minimal cutset.

Minimal separators play an important role in chordal graphs. In particular, it is well-known that every minimal separator of a chordal graph induces a clique. Moreover, the converse is also true.

Theorem 1. [8] *G is chordal if and only if every minimal separator of G is a clique.*

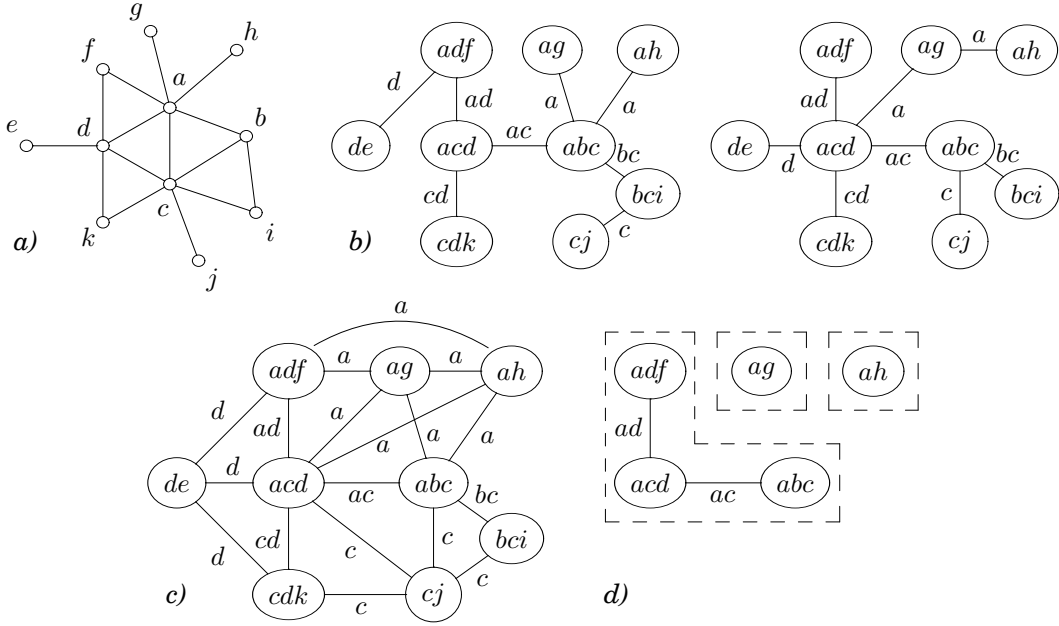

Figure 1: a) G , b) two example clique trees of G , c) $C_r(G)$, d) $\mathcal{H}_{\{a\}}$

1.3. Separating pairs

As mentioned above, every minimal separator of a chordal graph G is a clique, and hence, it is necessarily contained in a maximal clique of G . In fact, it turns out that it is contained in at least two maximal cliques, and moreover, it is precisely the intersection of these cliques. This is shown as follows (see also Lemma 2.3 in [2]).

Two maximal cliques C, C' of G form a *separating pair* if $C \cap C'$ is non-empty, and every path in G from a vertex of $C \setminus C'$ to a vertex of $C' \setminus C$ contains a vertex of $C \cap C'$.

Theorem 2. *A set S is a minimal separator of a chordal graph G if and only if there exist maximal cliques C, C' of G forming a separating pair such that $S = C \cap C'$.*

Proof. If maximal cliques C, C' of G form a separating pair, then $C \cap C'$ disconnects a vertex $a \in C \setminus C'$ from a vertex $b \in C' \setminus C$. Moreover, $C \cap C'$ is inclusion-wise minimal with this property, since for every $z \in C \cap C'$, the vertices a, z, b form a path from a to b . Finally, $C \cap C'$ is also non-empty by the definition of a separating pair, and hence, $S = C \cap C'$ is a minimal separator of G .

Conversely, let S be a minimal separator of G . That is, S is non-empty and there exist vertices a, b such that S disconnects a from b in G and no proper subset of S has this property. Let K_a and K_b be the two connected components of $G - S$ that contain a and b , respectively. Let x be a vertex of K_a with as many neighbours in S as possible among the vertices of K_a . Suppose that x is not adjacent to a vertex $w \in S$. Since S is a minimal separator, w has a neighbour y in K_a . Let P be a shortest path from x to y in K_a . Since $w \in N(y) \setminus N(x)$, we have on P consecutive vertices x', y' such that $N(x) \cap S = N(x') \cap S \neq N(y') \cap S$. In fact, by the maximality of x , there exists $w' \in (N(x') \setminus N(y')) \cap S$. We let P' denote the subpath of P from x' to y' , and conclude that $D = w', P', w, w'$ is a cycle in G where w', y' are neighbours of x' on this cycle with $w'y' \notin E(G)$. So, chordality of G implies that x' must have a neighbour in $D \setminus \{x', w', y'\}$, which is impossible because x' is not adjacent to w and P' is an induced path. Therefore, we conclude that $N(x) \cap S = S$, and by the same token, we have a vertex y in K_b with $N(y) \cap S = S$. So, if C and C' are maximal cliques of G that contain $S \cup \{x\}$ respectively $S \cup \{y\}$, then C, C' form a separating pair in G and $S = C \cap C'$ as required. \square

2. The reduced clique graph

Immediately from the respective definitions we have that every edge CC' of a clique tree of G is such that the cliques C, C' form a separating pair in G . This effectively inspires the following notion.

The *reduced clique graph* $\mathcal{C}_r(G)$ of G is the graph whose vertices are the maximal cliques of G , and whose edges CC' are between cliques C, C' forming separating pairs. Further, as in the case of clique trees, the edges of $\mathcal{C}_r(G)$ are labeled where edge CC' of $\mathcal{C}_r(G)$ has label $C \cap C'$. (See Figure 1c)

We remark that if G is disconnected, it follows from the definition that the reduced clique graph of G is the disjoint union of the reduced clique graphs of the connected components of G . It also follows that, conversely, if G is connected, then its reduced clique graph is also connected. Note that, unlike what is usual, we do not define clique trees for disconnected graphs, and in the subsequent text, having a clique tree will always imply that the considered graph and its reduced clique graph are connected.

From this definition, we can conclude that if G is connected, then every clique tree of G is a spanning tree of the reduced clique graph of G . Surprisingly, a much stronger statement is true, which was already proved in [5], and it is the following fundamental result about reduced clique graphs.

Theorem 3. [5] *Let G be a connected chordal graph. A tree T is a clique tree of G if and only if T is a maximum-weight spanning tree of $\mathcal{C}_r(G)$ where the weight of each edge CC' is defined as $|C \cap C'|$. Moreover, the reduced clique graph $\mathcal{C}_r(G)$ is precisely the union of all clique trees of G .*

Note that by [4] it is known that every connected chordal graph G has at most $|V(G)|$ maximal cliques. Consequently, the number of nodes in the reduced clique graph of G and in every clique tree of G is at most $|V(G)|$. In contrast, the number of edges in the reduced clique graph of G can be as large as $\Omega(|E(G)|^2)$; for instance, consider G to be a collection of edges sharing a common vertex.

2.1. Separator graphs

In order to understand the structure of reduced clique graphs, we now briefly study intersections of maximal cliques. As proved in Theorem 2, if two maximal cliques are adjacent in the reduced clique graph of G , then their intersection is necessarily a minimal separator (and hence it is non-empty). However, the converse is not always true (see nodes $\{adf\}$ and $\{abc\}$ in Figure 1c) and, as we shall see, we need to take into account a particular connectivity condition. We utilize special auxiliary graphs defined as follows.

Let $S \subseteq V(G)$. The *S -separator graph* of G , denoted by \mathcal{H}_S , is the graph whose vertices are the maximal cliques C of G with $S \subseteq C$, and edges are between cliques C, C' such that $C \cap C' \not\supseteq S$.

In other words, the \emptyset -separator graph is precisely the clique (intersection) graph of G , and if $S \neq \emptyset$, then \mathcal{H}_S is the intersection graph of the maximal cliques of $G - S$ whose vertices are completely adjacent to S in G . For instance, if G is the graph from Figure 1a, then the S -separator graph \mathcal{H}_S for $S = \{a\}$ is the graph depicted in Figure 1d. Note that this graph has three connected components.

Using the graphs \mathcal{H}_S , we now characterize the structure of the reduced clique graph $\mathcal{C}_r(G)$ by proving that two maximal cliques are “separated” by their intersection S if and only if they are in different connected components of the S -separator graph \mathcal{H}_S .

Theorem 4. *Let G be a chordal graph, let C and C' be two maximal cliques of G , and let $S = C \cap C'$. Then CC' is an edge of $\mathcal{C}_r(G)$ with label S if and only if S is non-empty, and C and C' belong to different connected components of \mathcal{H}_S .*

Proof. Suppose that S is non-empty, and C and C' are in different connected components of \mathcal{H}_S . Suppose that CC' is not an edge of $\mathcal{C}_r(G)$. Then C, C' is not a separating pair, and hence, since $S = C \cap C' \neq \emptyset$, there exists a path x_1, \dots, x_k from $x_1 \in C \setminus C'$ to $x_k \in C' \setminus C$ such that $x_i \notin S = C \cap C'$ for each $i \in \{1 \dots k\}$. It follows that x, x_1, \dots, x_k, x is a cycle in G for each $x \in S$. But G is chordal which implies that each vertex of S is adjacent to all of x_1, \dots, x_k . Now, let $C_1 = C$, $C_{k+1} = C'$, and for each

$i \in \{2 \dots k\}$, let C_i be a maximal clique of G containing $\{x_{i-1}, x_i\} \cup S$. Clearly, the cliques C_1, \dots, C_{k+1} all belong to \mathcal{H}_S . Also, $C_i C_{i+1}$ is an edge of \mathcal{H}_S for each $i \in \{1 \dots k\}$, since $C_i \cap C_{i+1} \supseteq S \cup \{x_i\} \not\subseteq S$. Hence, there is a path from $C_1 = C$ to $C_{k+1} = C'$ in \mathcal{H}_S contradicting that C, C' are in different connected components of \mathcal{H}_S .

Conversely, suppose that CC' is an edge of $\mathcal{C}_r(G)$ with label S . Then C, C' is a separating pair implying $S \neq \emptyset$. Suppose that C, C' belong to a connected component \mathcal{K} of \mathcal{H}_S . Then there is a path C_1, \dots, C_k in \mathcal{K} with $C_1 = C$ and $C_k = C'$. Since $C_i C_{i+1}$ is an edge of \mathcal{H}_S , there exist a vertex $x_i \in (C_i \cap C_{i+1}) \setminus S$ for each $i \in \{1 \dots k-1\}$. Clearly, $x_1 \in C$ and $x_{k-1} \in C'$. Also, $x_i \notin S = C \cap C'$ and $x_i x_{i+1}$ is an edge of G for each $i \in \{1 \dots k-2\}$. We conclude that x_1, \dots, x_{k-1} is a path in G from a vertex of $C \setminus C'$ to a vertex of $C' \setminus C$ with no vertex of $C \cap C'$. But then CC' is not an edge of $\mathcal{C}_r(G)$, a contradiction. \square

2.2. Structure of clique trees

In the previous paragraphs, we characterized the reduced clique graph of G using minimal separators. Based on this, we look back at the relationship between the clique trees and the reduced clique graph of G . By Theorem 3, every clique tree T of a connected chordal graph G is characterized in terms of $\mathcal{C}_r(G)$ as a maximum-weight spanning tree of $\mathcal{C}_r(G)$. Conversely, we characterize $\mathcal{C}_r(G)$ in terms of T as follows.

Theorem 5. *Let G be a connected chordal graph, let T be a clique tree of G , and let C, C' be two maximal cliques of G . Then CC' is an edge of $\mathcal{C}_r(G)$ with label $S = C \cap C'$ if and only if there exists an edge with label S on the path from C to C' in T .*

Proof. Let C, C' be two maximal cliques of G and let $S = C \cap C'$. Let P denote the path from C to C' in T . First, suppose that CC' is an edge of $\mathcal{C}_r(G)$ with label S . Then, by Theorem 4, the cliques C and C' belong to different connected components of \mathcal{H}_S . Moreover, since T is a clique tree, all cliques on P belong to \mathcal{H}_S . So, there must be consecutive cliques C^*, C^{**} on P that belong to different connected components of \mathcal{H}_S . By Theorem 4, the edge $C^* C^{**}$ has label S , and we are done.

Conversely, suppose that CC' is not an edge of $\mathcal{C}_r(G)$ but there is an edge $C^* C^{**}$ with label S on P . We conclude that S is a minimal separator, and hence, Theorem 4 yields that C and C' belong to the same connected component of \mathcal{H}_S . So, there exists a path $P' = C_1, \dots, C_k$ from $C_1 = C$ to $C_k = C'$ in \mathcal{H}_S . By the definition of P' , we have $C_i \cap C_{i+1} \not\subseteq S$ for each $i \in \{1 \dots k-1\}$. Now, we remove from T the edge $C^* C^{**}$ to obtain a subtree T_1 that contains C and a subtree T_2 that contains C' . Since $C_1 = C$ belongs to T_1 and $C_k = C'$ belongs to T_2 , there exists i such that C_i belongs to T_1 while C_{i+1} belongs to T_2 . Clearly, the path from C_i to C_{i+1} in T contains the edge $C^* C^{**}$. So, since T is a clique tree, we conclude $S = C^* \cap C^{**} \supseteq C_i \cap C_{i+1}$, a contradiction. Therefore, no edge on P has label S . \square

Finally, we can describe the structure of T in terms of the graphs \mathcal{H}_S as follows.

Theorem 6. *Let G be a connected chordal graph, and let T be a clique tree of G . Let S be a minimal separator of G , and let k_S denote the number of connected components of \mathcal{H}_S . Then T contains exactly $(k_S - 1)$ edges with label S , and each connected component of \mathcal{H}_S induces a connected subgraph in T .*

Proof. Let C, C' be two maximal cliques of G that belong to \mathcal{H}_S , and let P be the path from C to C' in T . We observe that every clique on P also belongs to \mathcal{H}_S , since T is a clique tree. It follows that the vertices of \mathcal{H}_S induce in T a connected subgraph. Next, suppose that C, C' belong to some connected component \mathcal{K} of \mathcal{H}_S . We show that every clique on P also belongs to \mathcal{K} . Suppose otherwise, let C^* be the first clique on P that lies outside \mathcal{K} . (Recall that P is a path from C to C'). Let C^{**} be the clique on P just before C^* . Thus, C^{**} belongs to \mathcal{K} , and hence, $C^* \cap C^{**} = S$ by Theorem 4. This implies that $C \cap C' = S$ because T is a clique tree. Thus, by Theorem 5, CC' is an edge of $\mathcal{C}_r(G)$ with label S . But C, C' both belong to \mathcal{K} which contradicts Theorem 4. Therefore, the vertices of \mathcal{K} induce a connected subgraph in T .

Finally, since both the vertices of \mathcal{H}_S and of each connected component of \mathcal{H}_S induce a subtree in T , it follows that T must contain exactly $(k_S - 1)$ edges with label S . \square

Note that if S is a minimal separator of G , then $k_S \geq 2$. This can be seen as follows. By Theorem 2, there are maximal cliques C, C' that form a separating pair such that $C \cap C' = S$. Thus, CC' is an edge of $\mathcal{C}_r(G)$ with label S , and, by Theorem 4, the cliques C and C' are in different connected components of \mathcal{H}_S . This implies $k_S \geq 2$. So, as a consequence of the above theorem, we have that every clique tree T of G contains at least one edge with label S which also shows that G has at most $|V(G)| - 1$ minimal separators, since T has at most $|V(G)|$ nodes as mentioned previously.

3. Split-minors

In this section, we focus on a different aspect of the structure of reduced clique graphs. We develop a decomposition[§] technique that will allow us to completely decompose any reduced clique graph using three natural reduction rules. We shall utilize this decomposition in later sections.

Let us start by explaining some intuition behind the decomposition. When considering clique trees (and tree representations), it is natural to perform certain operations on the (host) tree. In particular, removing and contracting edges of the tree are natural operations, since they result in one or more clique trees that represent specific subgraphs or supergraphs of the original graph. For this reason, the two operations are sometimes used to construct divide-and-conquer or greedy algorithms for problems on chordal graphs. Since we aim to argue that reduced clique graphs can be used algorithmically in place of clique trees (as a canonical substitute), we need to find similar operations on reduced clique graphs. Our goal therefore is the following:

- (G1) define edge contraction on reduced clique graphs,
- (G2) define edge removal on reduced clique graphs, and
- (G3) define the two operations so that the order in which they are performed is independent of the result.

First, let us look at contraction. Unlike the usual definition, to formally define contraction in clique trees and reduced clique graphs, we need to be a little careful. Note that we define clique trees and reduced clique graphs as graphs whose vertex set is a collection of sets as well as the edges of these graphs are labeled with sets. Thus the contraction operation on these graphs should reflect these facts. We define it as follows.

Let H be a graph whose vertices are sets and whose edges are labeled with sets. Let $e = C_1C_2$ be an edge of H . Then we write H/e for the graph obtained from H by *contracting* e into $C_1 \cup C_2$, that is,

- (i) we remove the nodes C_1 and C_2 , add a new node $C_1 \cup C_2$, and
- (ii) for each edge of H with label S between some vertex C and one of C_1, C_2 , we add a new edge with label S between C and $C_1 \cup C_2$.

Note that this operation (as just described) may create parallel edges. This is a real problem, and we shall deal with it in a moment. But before that, let us look at clique trees first where parallel edges are not an issue with respect edge contraction (since they do not contain cycles).

Let T be a clique tree of a chordal graph G and let $e = C_1C_2$ be an edge of T . Observe that that T/e is also a clique tree. Intuitively, we obtain T/e by treating the clique tree T as a tree representation (i.e., a host tree and its subtrees) and by contracting e in the host tree and all subtrees of the representation that contain e . Clearly, this operation does not remove any edges from G and only adds new edges between the vertices of C_1 and C_2 . In particular, T/e is a clique tree of the graph G' we obtain from G by adding all possible edges between the vertices of C_1 and C_2 . This implies that G' is a chordal graph.

[§]the word “reduction” would probably be more appropriate here, but we would like to avoid the confusion with the word “reduced” in “reduced clique graph”.

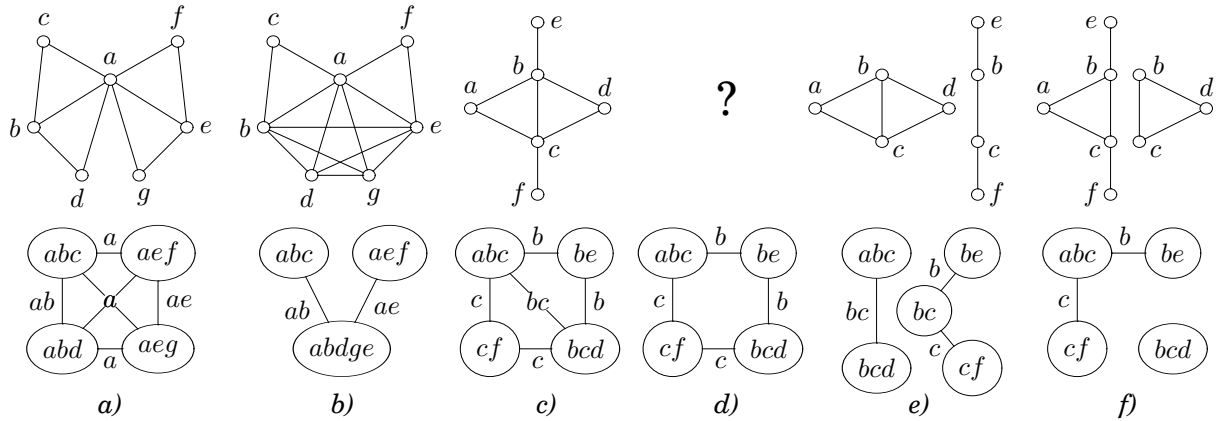

Figure 2: Examples justifying the definition of a split-minor.

In reduced clique graphs, as mentioned above, the operation of edge contraction may create parallel edges. Since we would like to deal with simple graphs, we need to decide how to remove parallel edges. Usually, one just removes all but one edge between any two vertices to obtain an equivalent simple graph. Unfortunately, parallel edges between same vertices may have different labels. We need to either *a)* decide which of them to keep, or *b)* use a rule to assign a label based on the labels of the parallel edges, or *c)* do not allow contractions that produce parallel edges with different labels. Further, in analogy to clique trees, we would like that the contraction of an edge C_1C_2 in the reduced clique graph of G produces the reduced clique graph of the graph G' obtained from G by adding all possible edges between the vertices of C_1 and C_2 . It turns out that *c)* is the only choice that also satisfies this constraint (as demonstrated in Figure 2ab). Thus this leads us to the following definition.

We say that an edge $e = C_1C_2$ of H is *permissible* if for every common neighbour C of C_1 and C_2 , the edges C_1C and C_2C have the same label. Clearly, if e is permissible, then contracting it in H creates parallel edges only between $C_1 \cup C_2$ and the common neighbours of C_1 and C_2 . All these edges have the same label S , and we therefore remove all but one of them to obtain a simple graph. Consequently, we write H/e for this (simple) graph from now on.

In the same fashion, we look at the second operation, the removal of edges. Again, we draw inspiration from clique trees. Let T be a clique tree of G and let $e = C_1C_2$ be an edge of T . Removing the edge e from T splits T into two connected components; let X and Y be the vertex sets of those components (vertices are maximal cliques of G), and let V_X be the union of cliques $C \in X$, and V_Y be the union of cliques $C \in Y$. By again treating T as a tree representation and restricting the host tree and subtrees to X , respectively Y , we observe that $T[X]$ and $T[Y]$ are clique trees of $G[V_X]$ and $G[V_Y]$, respectively.

Now, let us look at reduced clique graphs. Unlike in clique trees, we cannot simply remove an edge in a reduced clique graph and expect the result to be again a reduced clique graph or a disjoint union thereof (see Figure 2cd). We have to settle for the next best thing which is removing edges of cuts. (Note that in trees removing edges and removing edges of cuts are equivalent operations.)

A *cut* of a graph H is a partition $X \cup Y$ of $V(H)$ into two non-empty sets X and Y ; the edges of the cut $X \cup Y$ are the edges having one endpoint in X and one endpoint in Y . A *split* of H is a cut $X \cup Y$ of H such that every vertex of X with a neighbour in Y has the same neighbourhood in Y . (Note that we allow $|X| = 1$ and $|Y| = 1$ unlike it is usual [3, 18] when defining a split, sometimes called a *1-join*.) For a cut $X \cup Y$, we denote by V_X the union of the sets in X and by V_Y the union of the sets in Y .

In an analogy to clique trees, we only want to consider those cuts $X \cup Y$ of $C_r(G)$ for which $C_r(G)[X]$ is the reduced clique graph of $G[V_X]$ and $C_r(G)[Y]$ is the reduced clique graph of $G[V_Y]$. Moreover, to satisfy the condition (G3), we need to make sure that an edge is permissible in $C_r(G)[X]$ or $C_r(G)[Y]$ if and only if it is permissible in $C_r(G)$. This ultimately implies that all edges of the cut must have the same label, which in turn yields (by Theorem 4) that the cut, in fact, must be a split. For instance,

consider the graph G in Figure 2c; the partition $X = \{\{a, b, c\}, \{b, c, d\}\}$, $Y = \{\{b, e\}, \{c, f\}\}$ depicted in Figure 2e fails the first of the above conditions, since the reduced clique graph of $G[V_Y]$ is not $\mathcal{C}_r(G)[Y]$. Further, consider the the partition $X = \{\{a, b, c\}, \{b, e\}, \{c, f\}\}$, $Y = \{\{b, c, d\}\}$ in Figure 2f; the edge $\{a, b, c\}\{c, f\}$ is permissible in $\mathcal{C}_r(G)[X]$ but not in $\mathcal{C}_r(G)$. This leads to the following definition.

A split $X \cup Y$ of H is *permissible* if all edges of the split have the same label. Clearly, if an edge $e = C_1C_2$ in $H[X]$ is permissible, then it is also permissible in H , since the edges between C_1 , C_2 and their common neighbours in Y all have the same label because $X \cup Y$ is a permissible split. The same holds for the edges in $H[Y]$.

Now, combining the above operations yields the following notion.

We say that a graph H' is a *split-minor*[¶] of H if H' can be obtained from H by a (possibly empty) sequence of the following operations:

- (L1) if v is an isolated vertex, remove v .
- (L2) if e is a permissible edge, contract e .
- (L3) if $X \cup Y$ is a permissible split, remove all edges between X and Y .

We remark that the rule (L1) is included to allow us to deal with disconnected graphs.

In the following paragraphs, we prove that every split-minor of a reduced clique graph is again a reduced clique graph. We then discuss permissible edges and splits in reduced clique graphs, and as a consequence, we describe how this implies a decomposition of reduced clique graphs. For the main theorem, we need the following property of permissible edges.

Lemma 7. *Let G be a connected chordal graph, let $e = C_1C_2$ be a permissible edge of $\mathcal{C}_r(G)$, and let $S = C_1 \cap C_2$ be the label of e . Then $\{C_1\}$ and $\{C_2\}$ are connected components of \mathcal{H}_S .*

Proof. Clearly, both C_1 and C_2 are in \mathcal{H}_S because $S = C_1 \cap C_2$. Suppose that the component \mathcal{K} that contains C_1 has more than one clique. By Theorem 6, the set \mathcal{K} induces a connected subgraph in any clique tree of G . Hence, C_1 has a neighbour C^* in \mathcal{K} such that C_1C^* is an edge of $\mathcal{C}_r(G)$. This implies $C_1 \cap C^* \supsetneq S$ by Theorem 4, because C_1, C^* belong to the same component of \mathcal{H}_S . Also, C_1 and C_2 are in different components of \mathcal{H}_S because C_1C_2 is an edge of $\mathcal{C}_r(G)$ with label S . Hence, C^* and C_2 are in different components of \mathcal{H}_S , and we conclude, by Theorem 4, that C^*C_2 is also an edge of $\mathcal{C}_r(G)$ with label S . This creates a triangle C_1, C_2, C^* in $\mathcal{C}_r(G)$. However, C_1C^* and C_2C^* have different labels, and hence, $e = C_1C_2$ is not a permissible edge, a contradiction. We therefore conclude that $\mathcal{K} = \{C_1\}$ is a connected component of \mathcal{H}_S . By the same token, $\{C_2\}$ is a connected component of \mathcal{H}_S . \square

We are almost ready to prove the main theorem of this section. It only remains to discuss a particular technical subtlety of the statement. We would like to prove that if we remove edges of a permissible split $X \cup Y$ of the reduced clique graph of G , we obtain another reduced clique graph, namely, the reduced clique graph of $G' =$ the disjoint union of $G[V_X]$ and $G[V_Y]$ (where V_X and V_Y are defined as before). The problem is that some vertices of G may belong to both V_X and V_Y , and as such, they will appear in cliques of both $G[V_X]$ and $G[V_Y]$, and appear both on edges of $\mathcal{C}_r(G)[X]$ and $\mathcal{C}_r(G)[Y]$. However, in G' each vertex of $V_X \cap V_Y$ is represented by two distinct vertices. To fix this, we augment the operation (L3) to do the following after removing the edges between X and Y . For every $b \in V_X \cap V_Y$, we replace b by b' in each clique $C \in Y$ that contains b and update the labels of the affected edges (so that the label of each edge indicates the intersection of the two cliques that are the endpoints of the edge). Then when considering G' , the disjoint union of $G[V_X]$ and $G[V_Y]$, we implicitly assume that the vertices of $V_X \cap V_Y$ are replaced in $G[V_Y]$ by their prime ($'$) copies. This allows us to safely use the operation (L3). With this in mind, we can finally dive into the proof of the theorem.

[¶]the name was chosen in analogy with the notion of a *minor* where we remove, contract edges, and remove isolated vertices.

Theorem 8. *If H' is a split-minor of $\mathcal{C}_r(G)$, then there exists a chordal graph G' such that $H' = \mathcal{C}_r(G')$.*

Proof. By induction. Let H' be the graph obtained from $\mathcal{C}_r(G)$ by one of the three operations.

Case 1. We apply the rule (L1) to an isolated vertex of $\mathcal{C}_r(G)$. Then this vertex corresponds to a maximal clique C of G that forms a connected component of G , and hence, $\mathcal{C}_r(G - C) = H'$.

For the rules (L2) and (L3), we observe that if $\mathcal{C}_r(G)$ is disconnected then the operations (L2) and (L3) only affect one of its connected component while the other components remain the same. In fact, an edge is permissible in $\mathcal{C}_r(G)$ if and only if it is permissible in some connected component of $\mathcal{C}_r(G)$, and for every split of $\mathcal{C}_r(G)$, there exists an equivalent split of a connected component of $\mathcal{C}_r(G)$ where, in particular, the edges of two splits are the same. Also, by definition, $\mathcal{C}_r(G)$ is the disjoint union of the reduced clique graphs of the connected components of G , and it is connected if and only if G is. This implies that it suffices to prove the remaining cases for connected graphs.

Thus, in what follows, we shall assume that both G and $\mathcal{C}_r(G)$ are connected.

Case 2. We apply the rule (L2) to a permissible edge $e = C_1C_2$ of $\mathcal{C}_r(G)$ with label $S = C_1 \cap C_2$. In other words, $H' = \mathcal{C}_r(G)/_e$. Let G' be the graph we obtain from G by adding all possible edges between the vertices of C_1 and C_2 . We show G' is chordal and $\mathcal{C}_r(G') = \mathcal{C}_r(G)/_e$.

First, we look at the vertex sets of the two graphs. Since G is connected, there exists, by Theorem 3, a clique tree T of G that contains the edge e . By treating T as a tree representation and by contracting e in its host tree and all its subtrees, we conclude that $T/_e$ is a clique tree of G' . This implies that G' is chordal, and that the vertex set of $T/_e$ is the same as the vertex set of $\mathcal{C}_r(G')$. Also, by definition, the vertex sets of $T/_e$ and $\mathcal{C}_r(G)/_e$ are the same, since the vertex sets of T and $\mathcal{C}_r(G)$ are the same (T is a clique tree of G). This proves that the vertex sets of $\mathcal{C}_r(G')$ and $\mathcal{C}_r(G)/_e$ are the same.

It remains to consider edges.

(1) *Every edge of $\mathcal{C}_r(G')$ is also an edge of $\mathcal{C}_r(G)/_e$.*

Let CC' be an edge of $\mathcal{C}_r(G')$, and suppose that CC' is not an edge of $\mathcal{C}_r(G)/_e$. If neither of C, C' is the clique $C_1 \cup C_2$, then CC' is not an edge of $\mathcal{C}_r(G)$, and hence, there is a path P in G from a vertex of $C \setminus C'$ to a vertex of $C' \setminus C$ with no vertex of $C \cap C'$. However, G is a subgraph of G' , and hence, P is a path in G' implying that CC' is not an edge of $\mathcal{C}_r(G')$, a contradiction. So we may assume $C' = C_1 \cup C_2$. We conclude that we have no $a \in C \cap (C_1 \setminus C_2)$ or no $b \in C \cap (C_2 \setminus C_1)$, since otherwise a, b is a path from a vertex of $C_1 \setminus C_2$ to a vertex of $C_2 \setminus C_1$ implying that C_1C_2 is not an edge of $\mathcal{C}_r(G)$, a contradiction. So, without loss of generality, we may assume $C \cap C_2 \subseteq C_1$. Since CC' is not an edge of $\mathcal{C}_r(G)/_e$, both CC_1 and CC_2 are not edges of $\mathcal{C}_r(G)$, and hence, there exists in G a path P from a vertex of $C \setminus C_1 = C \setminus (C_1 \cup C_2)$ to a vertex of $C_1 \setminus C$ with no vertex from $C \cap C_1 = C \cap (C_1 \cup C_2)$. But then P is also a path in G' implying that CC' is not an edge of $\mathcal{C}_r(G')$, a contradiction.

(2) *Every edge of $\mathcal{C}_r(G)/_e$ is also an edge of $\mathcal{C}_r(G')$.*

Let CC' be an edge of $\mathcal{C}_r(G)/_e$, and suppose that CC' is not an edge of $\mathcal{C}_r(G')$. This implies that there exists a path in G' between a vertex of $C \setminus C'$ and a vertex of $C' \setminus C$ with no vertex in $C \cap C'$. Let P be a shortest such path, and let $a \in C \setminus C'$ and $b \in C' \setminus C$ be the endpoints of P .

First, suppose that C' is the clique $C_1 \cup C_2$. The minimality of P implies that b is the only vertex of $C_1 \cup C_2$ on P . Without loss of generality, suppose that $b \in C_1$. This implies that CC_1 is not an edge of $\mathcal{C}_r(G)$ because of the path P . Hence, Lemma 7 implies that C is not in \mathcal{H}_S , since otherwise C and C_1 are in different components of \mathcal{H}_S contradicting Theorem 4. Therefore, there exists $c \in S \setminus C$, and we conclude that CC_2 is not an edge of $\mathcal{C}_r(G)$ because P, c is a path from $a \in C \setminus C_2$ to $c \in C_2 \setminus C$ with no vertex of $C \cap C_2$. But then CC' is not an edge of $\mathcal{C}_r(G)/_e$, a contradiction.

So we may assume that neither of C, C' is the clique $C_1 \cup C_2$, and therefore, CC' is an edge of $\mathcal{C}_r(G)$. It follows that some edge xy of P does not belong to G . We must conclude $x, y \in C_1 \cup C_2$, and without loss of generality, we assume $x \in C_1 \setminus C_2, y \in C_2 \setminus C_1$, and the vertices a, x, y, b appear on P in this order. We further conclude that no vertex of $C_1 \cup C_2$ other than x, y belongs to P , because P is an induced path in G' . In particular, P contains no vertex of S and contains exactly two vertices of $C \cup C'$.

Now, let P_1 and P_2 denote the subpaths of P from a to x and from y to b , respectively. If there exists $c \in S \setminus (C \cap C')$, then P_1, c, P_2 is a path of G containing no vertex of $C \cap C'$ implying that CC' is not an edge of $\mathcal{C}_r(G)$, a contradiction. Hence, we must conclude $S \subseteq C \cap C'$, and so, C belongs to the graph \mathcal{H}_S . In particular, C and C_1 belong to different connected components of \mathcal{H}_S by Lemma 7, and hence, C_1C is an edge of $\mathcal{C}_r(G)$ with label S by Theorem 4. That is, $C_1 \cap C = S$ which implies that P_1 contains no vertex of $C_1 \cap C$. (Recall that P contains no vertex of S .) However, then P_1 is a path of G between $a \in C \setminus C_1$ and $x \in C_1 \setminus C$, and hence, CC_1 cannot be an edge of $\mathcal{C}_r(G)$, a contradiction.

Thus combining (1)-(2) yields $\mathcal{C}_r(G') = \mathcal{C}_r(G)/_e = H'$ as required.

Case 3. We apply the rule (L3) to a permissible split $X \cup Y$ of $\mathcal{C}_r(G)$ where S is the (common) label of the edges between X and Y . Let $V_X \subseteq V(G)$ denote the union of maximal cliques in the set X , and let $V_Y \subseteq V(G)$ denote the union of maximal cliques in the set Y . Let G' be the disjoint union of $G[V_X]$ and $G[V_Y]$. We show that $\mathcal{C}_r(G') = H'$. That is, we show $\mathcal{C}_r(G[V_X]) = \mathcal{C}_r(G)[X]$ and $\mathcal{C}_r(G[V_Y]) = \mathcal{C}_r(G)[Y]$.

First, we discuss the sets V_X, V_Y . In particular, we show the following property.

(3) $V_X \cap V_Y = S$ and there are no edges in G between the vertices in $V_X \setminus S$ and the vertices in $V_Y \setminus S$.

Since every vertex of G belongs to at least one maximal clique of G , we observe that every vertex of G belongs either to V_X or V_Y or both. Further, since there is at least one edge CC' in $\mathcal{C}_r(G)$ where $C \in X$ and $C' \in Y$ and this edge has label S , we have $S \subseteq C \subseteq V_X$ and $S \subseteq C' \subseteq V_Y$. Thus $S \subseteq V_X \cap V_Y$.

To prove that $S \supseteq V_X \cap V_Y$, suppose for contradiction that there exists $x \in (V_X \cap V_Y) \setminus S$. Since $x \in V_X \cap V_Y$, there is a clique $C \in X$ with $x \in C$, and a clique $C' \in Y$ with $x \in C'$. Let T be a clique tree of G , and let P be the path of T between C and C' . Since $C \in X$ and $C' \in Y$, there exist consecutive cliques C^*, C^{**} on P with $C^* \in X$ and $C^{**} \in Y$. So, $x \in C^* \cap C^{**}$, because $x \in C \cap C'$ and T is a clique tree. Further, T is a subgraph of $\mathcal{C}_r(G)$ by Theorem 3, and $X \cup Y$ is a permissible split. Hence, C^*C^{**} is an edge of $\mathcal{C}_r(G)$ with label S . But then $x \in S = C^* \cap C^{**}$, a contradiction.

Finally, we show that there are no edges between $V_X \setminus S$ and $V_Y \setminus S$. If otherwise, there are adjacent vertices $x \in V_X \setminus S$ and $y \in V_Y \setminus S$, and so there exists a maximal clique C of G with $x, y \in C$. If $C \in X$, then $y \in C \subseteq V_X$, and hence, $y \in V_X \cap V_Y = S$, a contradiction. So, $C \in Y$ but then $x \in V_X \cap C \subseteq V_X \cap V_Y = S$, a contradiction.

Now, we are ready to prove $\mathcal{C}_r(G') = H'$. By symmetry, it suffices to show $\mathcal{C}_r(G[V_X]) = \mathcal{C}_r(G)[X]$.

(4) X is the set of maximal clique of $G[V_X]$.

First, consider a clique $C \in X$. Since C is a clique of $G[V_X]$ by the construction of V_X , it is also a maximal clique of $G[V_X]$, because it is a maximal clique of G . Conversely, let C be a maximal clique of $G[V_X]$. Clearly, C is a clique of G , and hence, there exists a maximal clique C' of G with $C' \supseteq C$. Recall that we have at least one edge in $\mathcal{C}_r(G)$ between X and Y . Hence, at least one clique of $G[V_X]$ properly contains S , and so $C \setminus S \neq \emptyset$, because C is a maximal clique of $G[V_X]$. Also, recall that $V_X \cap V_Y = S$. So, $C' \in X$, since otherwise we have $C' \subseteq V_Y$, and hence, $C = C \cap C' \subseteq V_X \cap V_Y = S$, a contradiction. But then $C' \subseteq V_X$, and hence, $C' = C$ because C is a maximal clique of $G[V_X]$. So, we conclude $C \in X$.

This shows that $\mathcal{C}_r(G)[X]$ and $\mathcal{C}_r(G[V_X])$ have the same vertex set. It remains to consider edges.

(5) CC' is an edge of $\mathcal{C}_r(G)[X]$ if and only if it is an edge of $\mathcal{C}_r(G[V_X])$.

First, let CC' be any edge of $\mathcal{C}_r(G)[X]$. Then CC' is also an edge of $\mathcal{C}_r(G[V_X])$, since any path in $G[V_X]$ between a vertex of $C \setminus C'$ and a vertex of $C' \setminus C$ is also a path in G .

Conversely, let CC' be an edge of $\mathcal{C}_r(G[V_X])$. Suppose that CC' is not an edge in $\mathcal{C}_r(G)[X]$. Then there is a path in G between a vertex $a \in C \setminus C'$ and a vertex $b \in C' \setminus C$ that contains no vertex of $C \cap C'$. Let P be a shortest such path. Since CC' is an edge of $\mathcal{C}_r(G[V_X])$, at least one vertex of P lies outside V_X . Let x and y (possibly $x = y$) be respectively the first and the last vertex on P outside V_X . Since $a, b \in V_X$, we have on P a vertex x' just before x , and a vertex y' right after y . By the choice of x, y , we conclude $x', y' \in V_X$. Also, $x, y \in V_Y \setminus S$ since $x, y \notin V_X$ and $S \subseteq V_X$. So, since there are no edges between $V_X \setminus S$ and $V_Y \setminus S$, we must conclude $x', y' \in S$. But then P is not an induced path, since S is a clique by Theorem 1, a contradiction.

So, combining (4) and (5) yields $\mathcal{C}_r(V_X) = \mathcal{C}_r(G)[X]$. By symmetry, also $\mathcal{C}_r(V_Y) = \mathcal{C}_r(G)[Y]$, and hence, we obtain $\mathcal{C}_r(G') = H'$ as claimed. That concludes the proof. \square

We now show that every reduced clique graph contains permissible edges and splits. We say that an edge e of $\mathcal{C}_r(G)$ is *maximal* if there is no edge e' in $\mathcal{C}_r(G)$ whose label strictly contains the label of e . Similarly, an edge e is *minimal* if there is no edge e' whose label is strictly contained in the label of e .

We note in passing that these two types of edges correspond respectively to the max-min and min-min separators of [9] which play a particular role in the forbidden induced subgraph characterization of path graphs in [17].

Theorem 9. *Every maximal edge e in $\mathcal{C}_r(G)$ is permissible, and for every minimal edge e in $\mathcal{C}_r(G)$, there exists a permissible split $X \cup Y$ of $\mathcal{C}_r(G)$ such that e is an edge between the sets X and Y .*

Proof. Firstly, note that if an edge e is maximal, minimal, or permissible in $\mathcal{C}_r(G)$, then it is also respectively maximal, minimal, or permissible in some connected component of $\mathcal{C}_r(G)$. Further, a permissible split of the connected component of $\mathcal{C}_r(G)$ containing e can be augmented to a permissible split of $\mathcal{C}_r(G)$ by arbitrarily adding other connected components of $\mathcal{C}_r(G)$ to one or the other side of the partition. This implies that it suffices to prove the theorem for connected graphs G .

Let $e = C_1C_2$ be a maximal edge of $\mathcal{C}_r(G)$, and let C_1, C_2, C be a triangle in $\mathcal{C}_r(G)$ such that the edges C_1C and C_2C have different labels. That is, if we denote $S = C_1 \cap C_2$, $S_1 = C \cap C_1$, and $S_2 = C \cap C_2$, then we have $S_1 \neq S_2$. If $S_1 \subseteq S$ and $S_2 \subseteq S$, then we conclude $S_1 = S_2 = C \cap C_1 \cap C_2$. So, without loss of generality, we assume that there is $a \in S_1 \setminus S$. If also $b \in S \setminus S_1$, then a, b is path between a vertex of $C \setminus C_2$ and a vertex of $C_2 \setminus C$ with no vertex of $S_2 = C_2 \cap C$, but then C_2C is not an edge of $\mathcal{C}_r(G)$. We conclude $S \subseteq S_1$. However, e is a maximal edge, and hence, $S_1 \setminus S = \emptyset$, a contradiction.

Next, let $e = C_1C_2$ be a minimal edge of $\mathcal{C}_r(G)$ with label $S = C_1 \cap C_2$. Since G is connected, there exists, by Theorem 3, a clique tree of T that contains the edge e . If we remove the edge e from T , we obtain two subtrees; let X and Y denote the vertex sets of these two subtrees such that $C_1 \in X$ and $C_2 \in Y$. Further, let $X_0 \subseteq X$ denote the set all cliques $C \in X$ with $S \subseteq C$, and let $Y_0 \subseteq Y$ be the cliques $C \in Y$ with $S \subseteq C$. We show that if $C \in X$ and $C' \in Y$, then CC' is an edge of $\mathcal{C}_r(G)$ with label S if and only if $C \in X_0$ and $C' \in Y_0$. This will prove that $X \cup Y$ is a permissible split of $\mathcal{C}_r(G)$ as required.

Consider $C \in X$ and $C' \in Y$. Since T is a clique tree, we have $C \cap C' \subseteq C_1 \cap C_2 = S$. Hence, if CC' is an edge of $\mathcal{C}_r(G)$, we must conclude $C \cap C' = S$ by the minimality of e , and therefore, $C \in X_0$ and $C' \in Y_0$. Conversely, if $C \in X_0$ and $C' \in Y_0$, then $C \cap C' = S$ because $C \supseteq S$, $C' \supseteq S$, and $C \cap C' \subseteq S$. Moreover, the edge e lies on the path in T from C to C' . Hence, by Theorem 5, we conclude that CC' is an edge of $\mathcal{C}_r(G)$. \square

We remark that not every permissible edge of $\mathcal{C}_r(G)$ is necessarily maximal; for instance, the edge in Figure 1 labeled $\{a\}$ between the cliques $\{a, g\}$ and $\{a, h\}$ is permissible, but it is not maximal because $\{a, c\}$ is the label of the edge between the cliques $\{a, c, d\}$ and $\{a, b, c\}$.

We say that a graph is *totally decomposable* by a set of rules if there is a sequence of applications of the rules that reduces the graph to the empty graph (the graph with no vertices).

Combining the previous two results, we can now conclude the following.

Theorem 10 (Split-minor decomposition). *Every reduced clique graph is totally decomposable by the rules (L1) and (L2), and is also totally decomposable by the rules (L1) and (L3).*

Proof. Let $H = \mathcal{C}_r(G)$ be a minimal counterexample to the claim. Clearly, H has at least one vertex. If H contains no edges, then it has an isolated vertex, and we can apply (L1). So, H has an edge, which implies that it also has a minimal edge e and a maximal edge e' . But then Theorem 9 yields that e' is permissible, and hence, we can apply (L2). Also, H contains a permissible split $X \cup Y$ where e is one of the edges between X and Y , and we can apply (L3). So, H is not a minimal counterexample. \square

We close this section by noting an interesting connection between split-minors of reduced clique graphs and algorithms for finding a maximum-weight spanning tree. If G is connected, we can, by the above theorem, iteratively contract maximal edges in $\mathcal{C}_r(G)$ until the graph reduces to a single node. Clearly, the contracted edges yield a spanning tree T of $\mathcal{C}_r(G)$, and it is not difficult to see that T is, in fact, a clique tree of G . So, if at each step we choose an edge that is not only maximal but also has a largest label, we construct the same tree that Kruskal's algorithm [15] would on $\mathcal{C}_r(G)$. In other words, we construct a maximum-weight spanning tree. Conversely, if T is a clique tree of G , we can iteratively contract in $\mathcal{C}_r(G)$ the edges of T in decreasing order of their size, and each such edge is permissible at the time when we contract it. This provides us with an alternative and algorithmic proof of Theorem 3.

A similar conclusion can be reached by iteratively removing permissible splits based on edges with smallest labels. If $X \cup Y$ is a permissible split of $\mathcal{C}_r(G)$, then a clique tree of G can be obtained by finding clique trees for the chordal graphs corresponding to $\mathcal{C}_r(G)[X]$ and $\mathcal{C}_r(G)[Y]$, and then adding any edge from the edges of $\mathcal{C}_r(G)$ between X and Y . This behaviour can be observed in the Reverse-delete algorithm [12] for finding a maximum spanning tree, in which we remove minimum-weight edges unless they disconnect the graph; in our case, we remove all but one edge between X and Y .

4. Asteroidal number

In this section, we use the decomposition presented in Section 3, to characterize the asteroidal numbers of chordal graphs. Recall that a set A of vertices of G is *asteroidal* if for any $a \in A$, all vertices of $A \setminus \{a\}$ belong to one component of $G - N[a]$, and the *asteroidal number* $a(G)$ of G is the size of a largest asteroidal set in G . Note that if G is disconnected, then it follows from the definition that the asteroidal number of G is the maximum over the asteroidal numbers of its connected components.

4.1. Asteroidal collection of cliques

First, we show that the asteroidal number of a chordal graph depends solely on the structure of its reduced clique graph. We do this by relating it to a similar notion defined on reduced clique graphs.

We say that an edge e of $\mathcal{C}_r(G)$ is *hit* by a clique C if some edge of $\mathcal{C}_r(G)$ incident to C has the same label as e . We say that a path P of $\mathcal{C}_r(G)$ is *hit* by a clique C if some edge on P is hit by C . Otherwise, we say that P is *missed* by C , or that C *misses* P .

For instance, in Figure 1, the path P consisting of cliques $\{c, j\}$, $\{a, c, d\}$, $\{a, d, f\}$ is hit by the clique $\{b, c, i\}$, because the label of the edge between $\{c, j\}$ and $\{a, c, d\}$ is the same as the label of the edge between $\{c, j\}$ and $\{b, c, i\}$. However, P is missed by the clique $\{a, g\}$, since no edge of P has label $\{a\}$.

A collection \mathcal{A} of cliques of G is an *asteroidal collection of cliques* if for all distinct $C, C', C'' \in \mathcal{A}$, there is a path in $\mathcal{C}_r(G)$ from C to C' missed by C'' . As the reader would now expect, we shall prove, in what follows, that G contains an asteroidal set of size k if and only if $\mathcal{C}_r(G)$ contains an asteroidal collection of cliques consisting of k cliques. Before that, we need to show a couple of useful properties.

First, we remark that we shall implicitly make use of the following observation.

Lemma 11. *An edge e of $\mathcal{C}_r(G)$ with label S is hit by a clique C if and only if $S \subseteq C$.*

Proof. If e is hit by C , then some edge incident to C has label S implying $S \subseteq C$. Conversely, if $S \subseteq C$, then C belongs to \mathcal{H}_S . Since e has label S , there are, by Theorem 4, at least two connected components in \mathcal{H}_S . Hence, if C' is any clique in a connected component of \mathcal{H}_S different from that of C , then, by Theorem 4, CC' is an edge of $\mathcal{C}_r(G)$ with label S . So, e is hit by C , since CC' has the same label as e . \square

Next, using the following lemma will allow us to focus on clique trees only.

Lemma 12. *Let G be a connected chordal graph, let T be a clique tree of G , and let C_1, C_2, C_3 be distinct maximal cliques of G . Then every path between C_1 and C_2 in $\mathcal{C}_r(G)$ is hit by C_3 if and only if the path in T between C_1 and C_2 is hit by C_3 .*

Proof. The forward direction is obvious, since T is a spanning tree of $\mathcal{C}_r(G)$ by Theorem 3. For the backward direction, let P be a path in $\mathcal{C}_r(G)$ between C_1 and C_2 missed by C_3 , and let e be an edge on the path of T between C_1 and C_2 that is hit by C_3 . Let S denote the label of e . We conclude $S \subseteq C_3$. Now, let T_1, T_2 denote the two subtrees of T we obtain by removing the edge e from T where C_i belongs to T_i for $i = 1, 2$. Since C_1 is in T_1 but C_2 is in T_2 , there exists on P an edge e' having one endpoint in T_1 and the other in T_2 . Let S' denote the label of e' . We observe that the path of T between the endpoints of e' contains the edge e , since the endpoints are not both in T_1 or both in T_2 . It follows that $S' \subseteq S \subseteq C_3$, because T is a clique tree. So, C_3 hits e' , but then C_3 also hits P by Lemma 11. \square

Finally, we are ready to prove the theorem advertised earlier.

Theorem 13. $a(G) \geq k$ if and only if $\mathcal{C}_r(G)$ contains an asteroidal collection \mathcal{A} of cliques with $|\mathcal{A}| = k$.

Proof. Firstly, if G is disconnected, then also $\mathcal{C}_r(G)$ is disconnected, since $\mathcal{C}_r(G)$ is the disjoint union of the reduced clique graphs of the connected components of G . In particular, any asteroidal collection of cliques in $\mathcal{C}_r(G)$ is, by definition, an asteroidal collection in some connected component of $\mathcal{C}_r(G)$. Further, recall the asteroidal number of G is the maximum over asteroidal numbers of the connected components of G . This implies that it suffices to prove the theorem for connected graphs G .

Suppose that $a(G) \geq k$, and let $A = \{a_1, \dots, a_k\}$ be an asteroidal set of G of size k . For each $i \in \{1 \dots k\}$, let C_i denote any maximal clique of G that contains a_i . Clearly, $a_i \notin C_j$ and $C_i \neq C_j$ for each $i \neq j$, since no two vertices of A are adjacent. We show that $\mathcal{A} = \{C_1, \dots, C_k\}$ satisfies the claim.

Suppose otherwise, and without loss of generality, assume that every path from C_1 to C_2 in $\mathcal{C}_r(G)$ is hit by C_3 . In particular, if T is a clique tree of G , then the path of T between C_1 and C_2 contains an edge e hit by C_3 . Let S denote the label of e . We conclude $S \subseteq C_3$. Now, let T_1, T_2 denote the two subtrees of T we obtain by removing the edge e from T where C_i belongs to T_i for $i = 1, 2$. Recall that A is an asteroidal set. So, there exists a path P in G from a_1 to a_2 such that a_3 has no neighbour on this path. Since a_1 belongs to a clique in T_1 and a_2 belongs to a clique in T_2 , let us denote by y the first vertex on P that belongs to a clique in T_2 . Note that $y \neq a_1$, since otherwise a_1 belongs to both a clique in T_1 and in T_2 implying $a_1 \in S \subseteq C_3$ because T is a clique tree, a contradiction. Consequently, we have a vertex x before y on P , and x is in no clique of T_2 by the minimality of y . Since x, y are consecutive on P , we have $xy \in E(G)$, and hence, there is a clique in T_1 that contains both x, y . So $y \in S \subseteq C_3$, because y also belongs to a clique in T_2 . But then y is a neighbour of a_3 on P , a contradiction.

Conversely, let $\mathcal{A} = \{C_1, \dots, C_k\}$ be an asteroidal collection of cliques, and let T be any clique tree of G . Let T' denote the subgraph of T formed by taking all paths in T between the cliques C_1, \dots, C_k . Clearly, T' is a tree. Moreover, we show that C_1, \dots, C_k are the leaves of T' . Otherwise, we conclude, without loss of generality, that C_3 belongs to the path of T from C_1 to C_2 . But then C_3 hits this path which contradicts Lemma 12, since we assume that there is at least one path between C_1 and C_2 in $\mathcal{C}_r(G)$ missed by C_3 . So we let $C_i C'_i$ be the (unique) edge of T' incident to C_i , and let a_i be any vertex of G in $C_i \setminus C'_i$. Further, we define $A = \{a_1, \dots, a_k\}$. Clearly, A is an independent set of G , since for all i , the clique C_i is the only one in T' that contains a_i . We show that A is also an asteroidal set of G .

Suppose otherwise, and, without loss of generality, assume that a_1, a_2 are in different connected components of $G - N[a_3]$. Let $P = C^{(1)}, \dots, C^{(t)}$ be the path in T' from $C^{(1)} = C_1$ to $C^{(t)} = C_2$. By Lemma 12, P is missed by C_3 , and hence, no edge $C^{(i)} C^{(i+1)}$ of P satisfies $C^{(i)} \cap C^{(i+1)} \subseteq C_3$. Consequently, there exists x_i in $(C^{(i)} \cap C^{(i+1)}) \setminus C_3$ for each $i \in \{1 \dots t-1\}$, and $P' = a_1, x_1, \dots, x_{t-1}, a_2$ is a path in G from a_1 to a_2 . Now, recall that a_1, a_2 are in different connected components of $G - N[a_3]$. So a_3 has a neighbour x_i on P' , and since C_3 is a leaf of T' , we must conclude $x_i \in C_3$, a contradiction. \square

4.2. Good split-minors

In the previous section, we showed that the asteroidal number of G can be deduced from the reduced clique graph of G . To utilize this, we now investigate the structure of reduced clique graphs

with the help of the notion of a split-minor from Section 3. In particular, we show that we can contract or remove some edges of $\mathcal{C}_r(G)$ without increasing the asteroidal number of the corresponding graph.

To make this work, we need to introduce a special variant of the notion of a permissible edge. A clique C is said to be *S-dominated*,[†] if C is incident in $\mathcal{C}_r(G)$ to an edge with label S , and the label of every other edge incident to C is S or a subset of S or a superset of S .

An edge $e = C_1C_2$ of $\mathcal{C}_r(G)$ with label S is *good* if e is permissible in $\mathcal{C}_r(G)$, and no clique in $\mathcal{C}_r(G)$ is S -dominated unless at least one of C_1, C_2 is S -dominated.

For instance, the clique $\{a, g\}$ in Figure 1c is $\{a\}$ -dominated since all edges incident to $\{a, g\}$ have label $\{a\}$, but the clique $\{a, c, d\}$ is not $\{a\}$ -dominated because the edge between $\{a, c, d\}$ and $\{d, e\}$ has label $\{d\} \not\supseteq \{a\}$, $\{d\} \not\subseteq \{a\}$. Further, the edge between $\{a, g\}$ and $\{a, h\}$ is good because $\{a, g\}$ is $\{a\}$ -dominated, and the edge between $\{a, c, d\}$ and $\{a, b, c\}$ is good because no clique is $\{a, c\}$ -dominated.

We say that $\mathcal{C}_r(G')$ is a *good split-minor* of $\mathcal{C}_r(G)$ if $\mathcal{C}_r(G')$ can be obtained from $\mathcal{C}_r(G)$ by a (possibly empty) sequence of operations (L1), (L3), and the following operation:

(L2') if e is a good edge, contract e .

Theorem 14. *If $\mathcal{C}_r(G')$ is a good split-minor of $\mathcal{C}_r(G)$, then $a(G') \leq a(G)$.*

Proof. We proceed by induction. If $\mathcal{C}_r(G')$ is obtained from $\mathcal{C}_r(G)$ using the rule (L1) or (L3), then each connected component of G' is an induced subgraph of G , and hence, its asteroidal number is at most $a(G)$. This is implied by the fact that every path in an induced subgraph of G is also a path in G . Hence, since every asteroidal set of G' belongs necessarily to one of its connected components, we conclude $a(G') \leq a(G)$.

So, we may assume that $\mathcal{C}_r(G')$ is obtained from $\mathcal{C}_r(G)$ using the rule (L2') applied to a good edge $e = C_1C_2$ with label $S = C_1 \cap C_2$. If G is disconnected, note that $\mathcal{C}_r(G')$ is obtained by contracting e in some connected component of $\mathcal{C}_r(G)$. Recall that connected components of $\mathcal{C}_r(G)$ correspond to connected components of G , and the asteroidal number of G is the maximum over the asteroidal numbers of its components. This implies that it suffices to prove this case for connected graphs G .

By Theorem 8, recall that G' is obtained from G by adding all possible edges between the vertices in $C_1 \cup C_2$. Also, by Theorem 13, we have an asteroidal collection \mathcal{A} of cliques of G' where $|\mathcal{A}| = a(G')$.

Since G is connected, let T be a (fixed) clique tree of G that contains the edge e (such a clique tree is guaranteed by Theorem 3). Let T_1 and T_2 denote the two trees we obtain from T by removing the edge e such that C_i belongs to T_i for $i = 1, 2$.

Recall that $T/_e$ denotes the tree we obtain from T by contracting the edge $e = C_1C_2$ to $C_1 \cup C_2$. In particular, $T/_e$ is a clique tree of G' . So, by Lemma 12, we can conclude that

(*) *for all distinct C, C', C'' in \mathcal{A} , the path of $T/_e$ between C and C' is missed by C'' .*

Also, we shall make use of the following observation based on Lemma 7 and Theorem 4.

(**) *if a maximal clique C satisfies $S \subseteq C$, then C_1C and C_2C are edges of $\mathcal{C}_r(G)$ with label S .*

To prove this, we observe that $S \subseteq C$ implies that C is a vertex in \mathcal{H}_S , and, by Lemma 7, it is in a different connected component of \mathcal{H}_S than both C_1 and C_2 . So, by Theorem 4, we conclude that C_1C and C_2C are edges of $\mathcal{C}_r(G)$ with label S . This proves (**).

We remark that, for simplicity, if P is a path in T , we shall write $P/_e$ for the path of $T/_e$ corresponding to P . That is, $P/_e$ is obtained from P by (possibly) replacing cliques C_1, C_2 on P with the clique $C_1 \cup C_2$. Note that, by the construction of $T/_e$, the labels of edges on $P/_e$ are the same as the labels on P except (possibly) for the label S of the edge e . In other words, if a clique C hits an edge on P and this edge is not e , then C also hits the path $P/_e$.

[†]Note that this definition differs from the one that appears in [10] because, unfortunately, with that definition Theorem 14 is false (see Figure 4a for a particular counterexample).

First, we prove the following.

(1) *If $C_1 \cup C_2$ is in \mathcal{A} , then $a(G) \geq a(G')$.*

Suppose that the clique $C_1 \cup C_2$ is among the cliques in \mathcal{A} . If C, C' are two cliques in $\mathcal{A} \setminus \{C_1 \cup C_2\}$ such that C is in T_1 and C' in T_2 , then the path from C to C' in T/e contains $C_1 \cup C_2$, and hence, is hit by $C_1 \cup C_2$. But this contradicts (*), since $C, C', C_1 \cup C_2$ are cliques in \mathcal{A} . So we may assume, without loss of generality, that all cliques of \mathcal{A} different from $C_1 \cup C_2$ belong to T_1 . We show that $\mathcal{A}' = \mathcal{A} \setminus \{C_1 \cup C_2\} \cup \{C_1\}$ is an asteroidal collection of cliques of G . Suppose that for some $C, C', C'' \in \mathcal{A}'$, the path P between C and C' in T is hit by C'' . Since C, C' belong to T_1 , P is a path of T_1 , and hence, it does not contain the edge e . So, if C_1 is not among C, C', C'' , then P/e is a path of T/e from C to C' hit by C'' , which contradicts (*), since C, C', C'' belong to \mathcal{A} . Otherwise, if C_1 is among C, C' , say $C = C_1$, then P/e is a path of T/e from $C_1 \cup C_2$ to C' hit by C'' , again contradicting (*). Finally, if $C'' = C_1$, then P/e is a path between C, C' hit by $C_1 \cup C_2$, impossible by (*). This shows that \mathcal{A}' is an asteroidal collection of cliques of G . So, by Theorem 13, we conclude $a(G) \geq a(G')$ as required.

Now, we may assume that $C_1 \cup C_2$ is not in \mathcal{A} , and hence, \mathcal{A} is a collection of cliques of G . If \mathcal{A} is also an asteroidal collection of cliques of G , then we again conclude $a(G) \geq a(G')$ by Theorem 13, and we are done. So, we may assume that \mathcal{A} is not an asteroidal collection, and therefore, there exist cliques $C^{(1)}, C^{(2)}, C^{(3)} \in \mathcal{A}$ such that every path in $\mathcal{C}_r(G)$ from $C^{(1)}$ to $C^{(2)}$ is hit by $C^{(3)}$. In particular, the path P in T from $C^{(1)}$ to $C^{(2)}$ is hit by $C^{(3)}$. It follows that $C^{(3)}$ misses P/e , since otherwise we contradict (*). Therefore, we conclude that e is an edge of P , and $C^{(3)}$ hits e . In particular, $S \subseteq C^{(3)}$ which implies, by (**), that $C_1 C^{(3)}$ and $C_2 C^{(3)}$ are edges in $\mathcal{C}_r(G)$ with label S . Further, the cliques $C^{(1)}, C^{(2)}$ are not both in T_1 or both in T_2 , since e is on the path in T between $C^{(1)}$ and $C^{(2)}$. Hence, without loss of generality, we may assume that $C^{(i)}$ belongs to T_i for $i = 1, 2$, and $C^{(3)}$ belongs to T_2 . (Please refer to Figure 3a for a depiction of this and subsequent discussion.)

Since $C^{(1)}, C^{(2)}$ are cliques of G different from C_1, C_2 , the edge $e = C_1 C_2$ is not the first nor the last edge on P . Hence, there exist cliques C^+, C^{++} such that $e^+ = C_1 C^+$ and $e^{++} = C_2 C^{++}$ are edges of P different from e . We observe that if $S \subseteq C^+$, then (**) implies that the edge e^+ has label S . But then P/e is hit by $C^{(3)}$, contradicting (*). Hence, $C^+ \cap C_1 \not\subseteq S$. Moreover, $C^+ \cap C_1 \not\subseteq S$, since otherwise $C^+ \cap C_1 \subseteq S \subseteq C^{(3)}$ and e^+ is again hit by $C^{(3)}$. This shows that C_1 is not S -dominated. Similarly, we conclude that C_2 is not S -dominated. Hence, since e is a good edge, we conclude that $C^{(3)}$ is also not S -dominated. Recall that $C^{(3)}$ is incident to an edge $C_1 C^{(3)}$ with label S . This implies that there exists a clique C^* such that $C^{(3)} C^*$ is an edge of $\mathcal{C}_r(G)$ with label $S^* = C^{(3)} \cap C^*$ where $S^* \not\subseteq S$ and $S^* \not\subseteq S$.

Recall that $C^{(3)}$ belongs to T_2 . We conclude that C^* also belongs to T_2 , since otherwise the path P^* in T between $C^{(3)}$ and C^* contains the edge e which implies $S^* = C^{(3)} \cap C^* \subseteq S$, a contradiction. It follows that P^* is a path of T_2 , since both endpoints of P^* are in T_2 . Moreover, since $C^{(3)} C^*$ is an edge of $\mathcal{C}_r(G)$, we conclude, by Theorem 5, that P^* contains an edge e^* whose label is S^* . Therefore, we denote by $T_{2,1}$ and $T_{2,2}$ the two trees we obtain from T_2 by removing the edge e^* such that $C^{(3)}$ belongs to $T_{2,1}$. Clearly, C^* belongs to $T_{2,2}$. Moreover, C_2 belongs to $T_{2,1}$, since otherwise the path of T between C_2 and $C^{(3)}$ contains the edge e^* implying $S = C_2 \cap C^{(3)} \subseteq S^*$, a contradiction. Similarly, no clique C of \mathcal{A} belongs to $T_{2,2}$, since otherwise the path of T between C and $C^{(1)}$ contains the edge e^* implying that $C^{(3)}$ hits this path, which contradicts (*) because $e \neq e^*$. Finally, we are ready to prove the following.

(2) *The set $\mathcal{A}^* = \mathcal{A} \setminus \{C^{(3)}\} \cup \{C^*\}$ is an asteroidal collection of cliques of G .*

Suppose that \mathcal{A}^* is not an asteroidal collection of cliques of G , that is, there are cliques C, C', C'' in \mathcal{A}^* such that the path P'' of T from C to C' is hit by C'' . Let e'' be an edge of P'' hit by C'' , and let S'' be the label of e'' . First, suppose that $e'' = e$. That is, C'' hits e , and we conclude $S \subseteq C''$. So, by (**), $C_1 C''$ and $C_2 C''$ are edges of $\mathcal{C}_r(G)$ with label S . This also implies that $C'' \neq C^*$, since $S \subseteq C''$ but $S \not\subseteq C^*$ because $C^{(3)} \cap C^* \not\subseteq S$. Now, let P' denote the path of T from $C^{(1)}$ to $C^{(3)}$ (see Figure 3b). Since $C^{(1)}$ is in T_1 and $C^{(3)}$ is in T_2 , the path P' contains the edge e . Also, since $C_2 C^{(3)}$ is an edge of $\mathcal{C}_r(G)$ with label S , we conclude, by Theorem 5, that P' contains an edge e' , also with label S , on the subpath of P' between C_2 and $C^{(3)}$. But then $e' \neq e$ and P'/e is hit by C'' , contradicting (*).

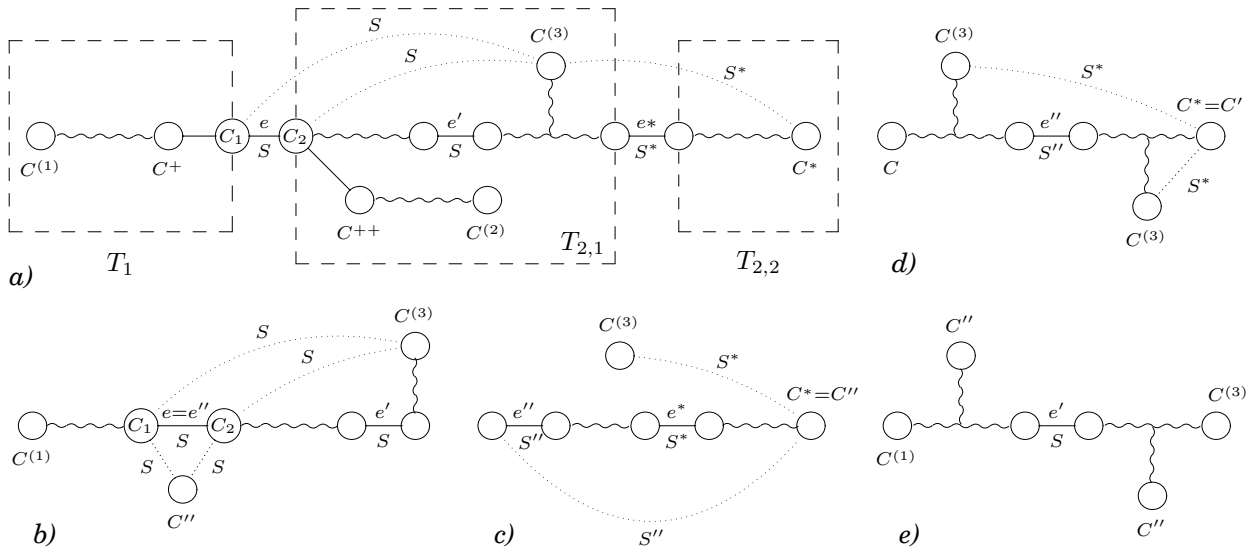

Figure 3: Cases in the proof of Theorem 14.

So, we may assume $e'' \neq e$, and hence, we conclude that C^* is one of C, C', C'' , since otherwise C, C', C'' are cliques in \mathcal{A} and P''/e is hit by C'' because $e'' \neq e$, contradicting (*).

First, suppose that $C'' = C^*$. Then C, C' are in \mathcal{A} , and hence, they do not belong to $T_{2,2}$ by the remark above. This implies that no clique on P'' is in $T_{2,2}$, and in particular, e'' is not an edge in $T_{2,2}$. However, C^* is in $T_{2,2}$, and hence, the path from C^* to the edge e'' contains the edge e^* (see Figure 3c). This implies $S^* \supseteq S''$, since T is a clique tree and $C^* = C'' \supseteq S''$. But then $C^{(3)} \supseteq S^* \supseteq S''$, and hence, P''/e is hit by $C^{(3)}$, contradicting (*).

Thus, we may assume that that C^* is among C, C' , say $C' = C^*$ by symmetry. If e'' belongs to the path P_1 of T between C and $C^{(3)}$ (see Figure 3d), then C'' hits P_1/e because $e'' \neq e$, contradicting (*). We conclude that e'' belongs to the path of T between $C^{(3)}$ and $C' = C^*$, because T is a tree. This implies $S'' \supseteq C^{(3)} \cap C^* = S^*$, because T is a clique tree. We conclude $S^* \subseteq S'' \subseteq C''$.

Now, consider again the path P' of T between $C^{(1)}$ and $C^{(3)}$. Again, P' contains the edge e , because $C^{(1)}$ in T_1 but $C^{(3)}$ in T_2 . Further, by Theorem 5, P' also contains an edge e' , different from e , also with label S , on the subpath of P' between C_2 and $C^{(3)}$, because $C_2C^{(3)}$ is an edge of $\mathcal{C}_r(G)$ (see Figure 3e). We conclude that e' does not appear on the path P_2 of T between $C^{(1)}$ and C'' , since otherwise $C^{(3)}$ hits P_2/e because $e' \neq e$, contradicting (*). So e' belongs to the path of T between $C^{(3)}$ and C'' because T is a tree, and hence, $S \supseteq C^{(3)} \cap C''$ because T is a clique tree. However, $C^{(3)} \cap C'' \supseteq S^*$ because $C'' \supseteq S^*$ and $C^{(3)} \supseteq S^*$, and hence, we obtain $S \supseteq S^*$ which is a contradiction.

This proves that \mathcal{A}^* is an asteroidal collection of cliques of G , and $|\mathcal{A}^*| = |\mathcal{A}| = a(G')$. Therefore, by Theorem 13, we conclude $a(G) \geq a(G')$ as required. \square

We remark that the above theorem does not hold for arbitrary split-minors. For instance, consider the graph G shown at the top of Figure 4a where $\mathcal{C}_r(G)$ is the graph at the bottom of Figure 4a. Then the edge between cliques $\{a, b, c\}$ and $\{b, c, d\}$ is permissible, and contracting it creates a graph G' shown with its reduced clique graph in Figure 4b. Clearly, $\{e, g, h, i\}$ is an asteroidal set in G' , but not in G . In fact, it can be easily verified that $a(G) = 3$ whereas $a(G') = 4$. Observe that the contracted edge is also maximal. However, it is not good because the clique $\{b, c, g\}$ is $\{b, c\}$ -dominated, but neither $\{a, b, c\}$ nor $\{b, c, d\}$ is $\{b, c\}$ -dominated.

We close by noting that the restrictions introduced in the operation (L2') still allow for a total decomposition of reduced clique graphs.

Theorem 15. *Every reduced clique graph is totally decomposable by the rules (L1) and (L2').*

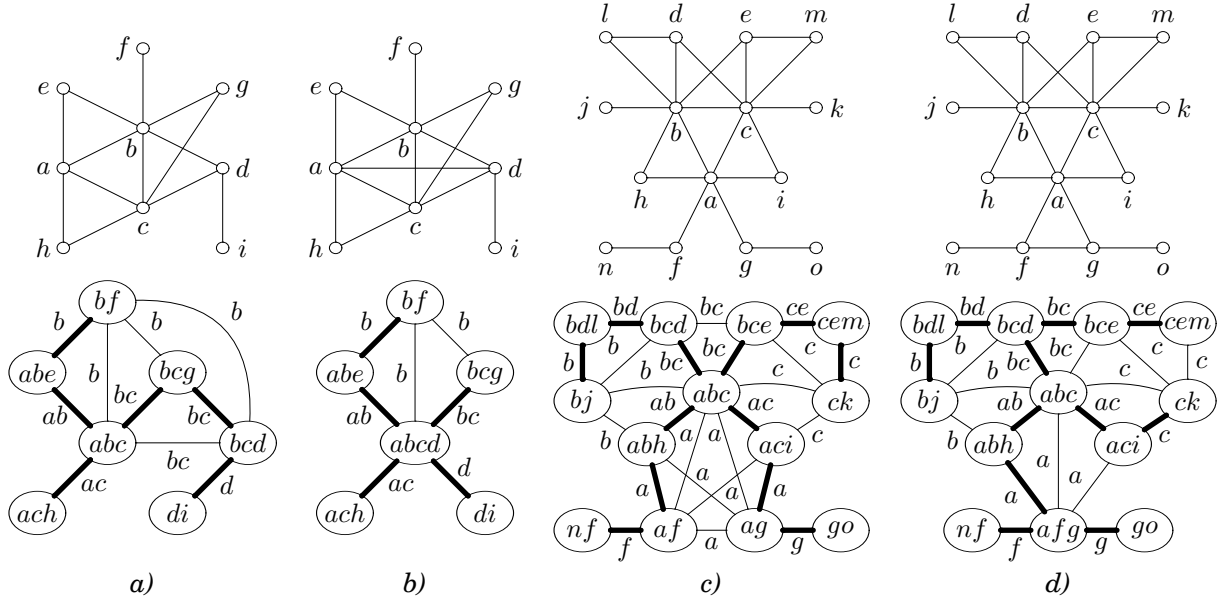

Figure 4: Examples justifying the definition of a good edge.

Proof. If $\mathcal{C}_r(G)$ contains no edge, then we can apply (L1). Otherwise, $\mathcal{C}_r(G)$ has an edge, and so, it also has a maximal edge e . Let S be the label of e . Recall that by Theorem 9, any maximal edge of $\mathcal{C}_r(G)$ is permissible. So, if e is not good, there must exist an S -dominated clique C . Since C is S -dominated, it is incident to an edge e' with label S . Hence, e' is also maximal, and so it is permissible by Theorem 9. Consequently, e' is good, because C is S -dominated, and we can apply (L2'). \square

4.3. Forbidden split-minor characterization

Recall that, by Theorem 14, if $a(G) \leq k$, then also for every good split-minor $\mathcal{C}_r(G')$ of $\mathcal{C}_r(G)$ we have $a(G') \leq k$. So, since good split-minor is a partial order with no infinitely decreasing chain, this provides us with a way to characterize the chordal graphs with asteroidal number at most k by “forbidding” split-minors. We say that $\mathcal{C}_r(G)$ is a *minimal forbidden split-minor for asteroidal number k* , if $a(G) > k$ and each proper good split-minor $\mathcal{C}_r(G')$ of $\mathcal{C}_r(G)$ satisfies $a(G') \leq k$. Then $a(G) \leq k$ if and only if no minimal forbidden split-minor for asteroidal number k is a good split-minor of $\mathcal{C}_r(G)$.

For instance, if G is the graph in Figure 5a where $\mathcal{C}_r(G)$ is depicted as Figure 5b, then $a(G) \geq k$ as witnessed by the set $A = \{b_1, \dots, b_k\}$. Moreover, every proper good split-minor $\mathcal{C}_r(G')$ of $\mathcal{C}_r(G)$ is obtained by contracting (or removing) some edges with labels a_i which implies $a(G') \leq k - 1$. Hence, we conclude that $\mathcal{C}_r(G)$ is a minimal forbidden split-minor for asteroidal number $k - 1$.

We remark that the above $\mathcal{C}_r(G)$ is, what we call, a labeled k -star. More precisely, a *labeled k -star* is any graph formed by taking k labeled edges that share a vertex (the labels of edges are arbitrary).

As we now prove, it turns out that every reduced clique graph that is a labeled k -star is a minimal forbidden split-minor for asteroidal number $k - 1$, and conversely, every minimal forbidden split-minor for asteroidal number $k - 1$ is a labeled k -star. This yields a single graph (up to the labels of edges) characterizing each asteroidal number in chordal graphs using the good split-minor ordering.

Theorem 16. *If $k \geq 3$, then $a(G) < k$ if and only if no labeled k -star is a good split-minor of $\mathcal{C}_r(G)$.*

Proof. Suppose that a labeled k -star $\mathcal{C}_r(G')$ is a good split-minor of $\mathcal{C}_r(G)$. Let C, C_1, \dots, C_k be the cliques $\mathcal{C}_r(G')$ where CC_i for $i = 1 \dots k$ are the edges of $\mathcal{C}_r(G')$. We show that $\mathcal{A} = \{C_1, \dots, C_k\}$ is an asteroidal collection of cliques of G' . Note that, since $\mathcal{C}_r(G')$ is itself a tree, this implies that G'

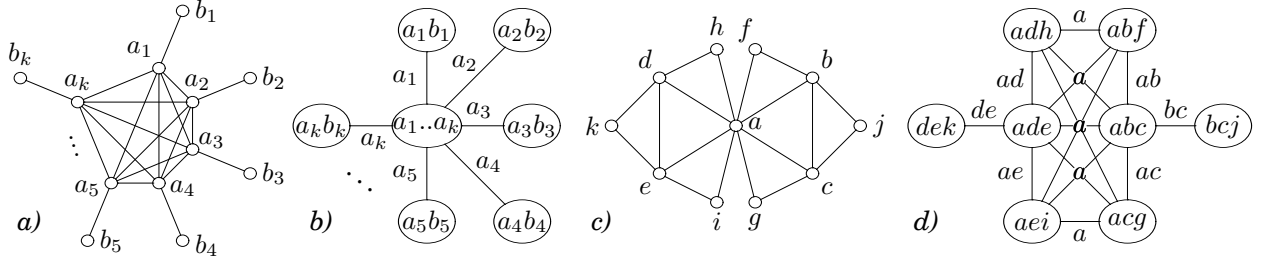

Figure 5: Examples of minimal forbidden split-minors.

is connected and that $T = \mathcal{C}_r(G')$ is the unique clique tree of G' by Theorem 3. To show that \mathcal{A} is an asteroidal collection, it suffices to show that no clique C_i hits any edge of $\mathcal{C}_r(G')$ other than CC_i . Without loss of generality, suppose that C_2 hits the edge CC_1 whose label is S . We conclude $S \subseteq C_1 \cap C_2$, and since CC_1 is on the path of T from C_1 to C_2 , we also conclude $C_1 \cap C_2 \subseteq S$. But then $C_1 \cup C_2 = S$, and hence, by Theorem 5, $C_1 C_2$ is an edge of $\mathcal{C}_r(G')$, a contradiction. So, since \mathcal{A} is an asteroidal collection of cliques of G' , we conclude $a(G') \geq |\mathcal{A}| = k$ by Theorem 13, and since $\mathcal{C}_r(G')$ is a good split-minor of $\mathcal{C}_r(G)$, we obtain $a(G) \geq a(G') \geq k$ by Theorem 14 as required.

For the converse, let G be a graph such that $\mathcal{C}_r(G)$ is a minimal forbidden split-minor for asteroidal number $k - 1$. That is, $a(G) \geq k$ and each proper good split-minor $\mathcal{C}_r(G')$ of $\mathcal{C}_r(G)$ satisfies $a(G') \leq k - 1$. By the remark above the theorem, it suffices to show that $\mathcal{C}_r(G)$ is a labeled k -star.

Since $a(G) \geq k$, there exists, by Theorem 13, an asteroidal collection \mathcal{A} of cliques of G with $|\mathcal{A}| = k$. By definition, the set \mathcal{A} belongs to some connected component of $\mathcal{C}_r(G)$. Thus, the minimality of $\mathcal{C}_r(G)$ implies that $\mathcal{C}_r(G)$ is connected, and hence, also G is connected. In particular, by Lemma 12, we have the following property.

(*) for every clique tree T of G and all C, C', C'' in \mathcal{A} , the path of T between C and C' is missed by C'' .

For more clarity, we present the proof as a series of simpler claims.

(1) No two cliques in \mathcal{A} are adjacent in $\mathcal{C}_r(G)$.

Let C_1, C_2 be cliques in \mathcal{A} such that $e = C_1 C_2$ is an edge of $\mathcal{C}_r(G)$. By Theorem 3, let T be a clique tree of G that contains the edge e , and let T_1, T_2 be the two trees we obtain from T by removing the edge e such that C_i is in T_i for $i = 1, 2$. Since $k \geq 3$, there exists a clique C_3 in \mathcal{A} different from C_1, C_2 . Without loss of generality, we may assume that C_3 belongs to T_1 , and so, the path of T from C_3 to C_2 contains the edge e . But then C_1 hits this path which contradicts (*).

(2) Every maximal good edge of $\mathcal{C}_r(G)$ is incident to one of the cliques in \mathcal{A} .

Let $e = C_1 C_2$ be a maximal good edge of $\mathcal{C}_r(G)$ such that both C_1 and C_2 are not in \mathcal{A} . Let G' be the graph we obtain from G by adding all possible edges between the vertices of $C_1 \cup C_2$. It follows from the proof of Theorem 8 that $\mathcal{C}_r(G') = \mathcal{C}_r(G)/_e$. Since $C_1, C_2 \notin \mathcal{A}$, we conclude that \mathcal{A} is a collection of cliques of G' . We show that \mathcal{A} is also an asteroidal collection of cliques of G' . If otherwise, there are cliques C, C', C'' in \mathcal{A} such that every path in $\mathcal{C}_r(G)/_e$ between C and C' is hit by C'' . However, by (*), there exists a path P in $\mathcal{C}_r(G)$ between C and C' missed by C'' . Let $P/_e$ denote the corresponding path in $\mathcal{C}_r(G)/_e$, that is, $P/_e$ is obtained from P by (possibly) replacing the cliques C_1, C_2 by $C_1 \cup C_2$. It follows that if S is the label of an edge of $P/_e$, then P also contains an edge with label S . So, since P is missed by C'' , also $P/_e$ is missed by C'' , but $P/_e$ is a path in $\mathcal{C}_r(G)/_e$ between C and C' , a contradiction.

Now, since \mathcal{A} is an asteroidal collection of cliques of G' , we conclude $a(G') \geq k$ by Theorem 13. However, $\mathcal{C}_r(G')$ is a proper good split-minor of $\mathcal{C}_r(G)$, which contradicts the minimality of $\mathcal{C}_r(G)$.

(3) For every permissible split $X \cup Y$ of $\mathcal{C}_r(G)$, we have $X \cap \mathcal{A} \neq \emptyset$ and $Y \cap \mathcal{A} \neq \emptyset$.

Suppose otherwise, and without loss of generality, assume $Y \cap \mathcal{A} = \emptyset$. Let S denote the common label of the edges between X and Y . Let T be a clique tree of G such that $T[X]$ has the most possible edges.

We show that $T[X]$ is connected. Suppose otherwise, and let C, C' be cliques in different components of $T[X]$ such that the path P of T between C and C' has smallest possible length. Let C^* be the clique on P right after C , and C^{**} be the clique on P just before C' (possibly $C^* = C^{**}$). By the minimality of C, C' , we have $C^*, C^{**} \in Y$. Since T is a subgraph of $\mathcal{C}_r(G)$ by Theorem 3, we conclude $C \cap C^* = C' \cap C^{**} = S$ which implies $C \cap C' \supseteq S$. Also, $C \cap C' \subseteq C \cap C^* = S$ because T is a clique tree. So, by Theorem 5, CC' is an edge of $\mathcal{C}_r(G)$ with label S . Now, let T' be constructed from T by replacing the edge CC^* by the edge CC' . Clearly, T' is a tree, and it is also a clique tree of G by Theorem 3, since it has the same weight as T . However, $T'[X]$ has more edges than $T[X]$, contradicting the choice of T .

Now, let V_X denote the union of all cliques in X . The proof of Theorem 8 implies that $\mathcal{C}_r(G[V_X]) = \mathcal{C}_r(G)[X]$. So, since $T[X]$ is connected, we conclude that $T[X]$ is a clique tree of $G[V_X]$. Moreover, every clique in \mathcal{A} is also a clique of $G[V_X]$ because $Y \cap \mathcal{A} = \emptyset$. Hence, it follows from (*) that \mathcal{A} is an asteroidal collection of cliques of $G[V_X]$. So, by Theorem 13, we conclude $a(G[V_X]) \geq k$, but this contradicts the minimality of $\mathcal{C}_r(G)$, since $\mathcal{C}_r(G[V_X])$ is a proper good split-minor of $\mathcal{C}_r(G)$.

(4) *Every edge of $\mathcal{C}_r(G)$ is minimal, maximal and good.*

Suppose otherwise, and let e_0 be any edge of $\mathcal{C}_r(G)$ that violates the claim and has smallest possible label. Let S_0 denote the label of e_0 . We claim that e_0 is a minimal edge of $\mathcal{C}_r(G)$. If otherwise, there exists an edge e' with label $S' \subsetneq S_0$. So, e' is not a maximal edge of $\mathcal{C}_r(G)$, and hence, it also violates the claim. But this contradicts the choice of e_0 , since the label of e' is smaller than the label of e_0 .

Next, by Theorem 3, let T be a clique tree of G that contains the edge e_0 . Let X, Y denote the vertex sets of the two subtrees we obtain from T by removing e_0 . Since e_0 is a minimal edge of $\mathcal{C}_r(G)$, we conclude, using the proof of Theorem 9, that $X \cup Y$ is a permissible split of $\mathcal{C}_r(G)$. In particular, we have $\mathcal{A} \cap X \neq \emptyset$ and $\mathcal{A} \cap Y \neq \emptyset$ by (3).

Now, we have two possibilities. If e_0 is not a maximal edge of $\mathcal{C}_r(G)$, then $\mathcal{C}_r(G)$ contains a maximal edge e , distinct from e_0 , whose label contains S_0 . We may assume that e is also good, since otherwise we can use the proof of Theorem 15 to replace e with a good edge having the same label.

If e_0 is a maximal edge of $\mathcal{C}_r(G)$, then it is not good because it violates the claim. Thus, again by the proof of Theorem 15, there exists a maximal good edge e , distinct from e_0 , whose label is S_0 .

In both cases, we find a good maximal edge e , distinct from e_0 , whose label S satisfies $S \supseteq S_0$. Subject to this, we shall assume that e is chosen so that it has both endpoints in X or in Y if possible.

Since e is maximal and good, one of the cliques C_1, C_2 belongs to \mathcal{A} by (2). Without loss of generality, we assume that $C_1 \in \mathcal{A}$, and by symmetry, we also assume that C_1 belongs to Y . By (1), we have $C_2 \notin \mathcal{A}$, and we further conclude that C_1 is the only clique of \mathcal{A} in Y . If otherwise, there is another clique $C' \in \mathcal{A} \cap Y$, and the path of T from C' to any clique of $\mathcal{A} \cap X$ contains the edge e_0 . Hence, this path is hit by C_1 , since $S_0 \subseteq S \subseteq C_1$, but that contradicts (*).

Now, let G' be the graph we obtain from G by adding all possible edges between vertices of $C_1 \cup C_2$. By Theorem 8, we conclude that $\mathcal{C}_r(G') = \mathcal{C}_r(G)/_e$. We show that $\mathcal{A}^* = \mathcal{A} \setminus \{C_1\} \cup \{C_1 \cup C_2\}$ is an asteroidal collection of cliques of G' . Suppose otherwise, and let C, C', C'' be cliques in \mathcal{A}^* such that every path in $\mathcal{C}_r(G)/_e$ between C and C' is hit by C'' . If P is a path in $\mathcal{C}_r(G)$, we as usual write $P/_e$ for the corresponding path in $\mathcal{C}_r(G)/_e$ obtained by (possibly) replacing cliques C_1, C_2 on P by $C_1 \cup C_2$. We again conclude that the label of each edge of $P/_e$ appears on some edge of P .

First, if $C_1 \cup C_2$ is not among C, C', C'' , then $C, C', C'' \in \mathcal{A}$, and the path P of T between C and C' is missed by C'' by (*). Hence, $P/_e$ is a path of $\mathcal{C}_r(G)/_e$ between C and C' missed by C'' , a contradiction. Similarly, if $C_1 \cup C_2$ is among C, C' , say $C' = C_1 \cup C_2$, then $C, C'' \in \mathcal{A}$ and the path P of T between C and C_1 is missed by C'' by (*). But then $P/_e$ is a path in $\mathcal{C}_r(G)/_e$ between C and $C' = C_1 \cup C_2$ missed by C'' .

So, we may assume that $C'' = C_1 \cup C_2$. Thus $C, C' \in \mathcal{A}$, and we let P denote the path of T between C and C' . Recall that we assume that all cliques in \mathcal{A} except for C_1 belong to X . Then also each clique on P is in X , since C, C' are in X and $T[X]$ is connected. By (*), we conclude that C_1 misses P .

If C_2 also misses P , then we conclude that $P/_e$ is missed by $C'' = C_1 \cup C_2$, since the label of each edge incident to $C_1 \cup C_2$ in $\mathcal{C}_r(G)$ appears on some edge incident to C_1 or C_2 in $\mathcal{C}_r(G)$. This contradicts our assumption, and hence, we may assume that C_2 hits P . In particular, let e^* be an edge of P hit by

C_2 , and let S^* denote the label of e^* . Recall that $C_1 \in Y$ and all cliques on P are in X . If also $C_2 \in Y$, then the path of T between C_2 and the edge e^* contains e_0 , and we conclude $S^* \subseteq S_0$ because T is a clique tree. However, then C_1 hits P since $S_0 \subseteq C_1$, which contradicts (*).

So, we may assume $C_2 \in X$, and hence, $S_0 = S$ because $X \cup Y$ is a permissible split. Consequently, e_0 is a maximal edge and thus it is not good because we assume that it violates the claim. Now, suppose that both C_1 and C_2 are not S -dominated. Recall that e is good and maximal. Hence, it is also permissible by Theorem 9 which implies, by the definition of a good edge, that no clique in G is S -dominated, since we assume that neither C_1 nor C_2 is. But then e_0 is good, since it is also permissible and $S_0 = S$, a contradiction. This implies that one of C_1, C_2 is S -dominated.

Suppose first that C_1 is S -dominated, and let C^* be the endpoint of e_0 that belongs to Y . We conclude $C_1 \neq C^*$, since otherwise e_0 is good. Also, C^* is in \mathcal{H}_S because $C^* \supseteq S_0 = S$, and in fact, C_1 and C^* are in different connected components of \mathcal{H}_S by Lemma 7, because e is permissible. So, by Theorem 4, C_1C^* is an edge of $\mathcal{C}_r(G)$ with label S , and hence, C_1C^* is good, because C_1 is S -dominated. But this contradicts the choice of e , since both C_1, C^* belong to Y . Hence, C_2 must be S -dominated, and since e is maximal and C_2 hits e^* , we conclude $S^* \subseteq S$. Then C_1 hits P , because $S \subseteq C_1$, contradicting (*).

This shows that \mathcal{A}^* is an asteroidal collection of cliques of G' , and hence, $a(G') \geq k$ by Theorem 13. However, this contradicts the minimality of $\mathcal{C}_r(G)$, since $\mathcal{C}_r(G')$ is a proper good split-minor of $\mathcal{C}_r(G)$.

(5) $\mathcal{C}_r(G)$ is a tree.

Let T be any clique tree of $\mathcal{C}_r(G)$. If $\mathcal{C}_r(G)$ is not a tree, there exists an edge $e = C_1C_2$ of $\mathcal{C}_r(G)$ that is not an edge of T . Let S denote the label of e . Since e is not in T , there is at least one clique C different from C_1, C_2 on the path of T between C_1 and C_2 . Clearly, $S \subseteq C$ because T is a clique tree. By (4), we conclude that e is good, and hence, it is permissible. So, by Lemma 7, C is in a different connected component of \mathcal{H}_S than both C_1, C_2 , and, by Theorem 4, we have that C, C_1, C_2 is a triangle in $\mathcal{C}_r(G)$. We now observe, by (1), that at most one of C, C_1, C_2 belongs to \mathcal{A} . Hence, one of the edges of the triangle C, C_1, C_2 is not incident to a clique in \mathcal{A} , and is good and maximal by (4). But this contradicts (2).

(6) The diameter of $\mathcal{C}_r(G)$ is at most two.

Let T be a clique tree of G . Since $\mathcal{C}_r(G)$ is a tree by (5), we conclude $T = \mathcal{C}_r(G)$ by Theorem 3. If the diameter of T is more than two, then T contains an induced path with cliques C_1, C_2, C_3, C_4 and edges C_1C_2, C_2C_3, C_3C_4 . By (2) and (4), one of C_2, C_3 is in \mathcal{A} . Without loss of generality, assume $C_2 \in \mathcal{A}$.

Consider the edges $e_1 = C_1C_2$ and $e_2 = C_2C_3$. By (4), the edges e_1, e_2 are minimal. For $i = 1, 2$, let X_i, Y_i denote the vertex sets of the subtrees we obtain by removing e_i from T where $C_2 \in X_i$. Using the proof of Theorem 9, we conclude that $X_i \cup Y_i$ is a permissible split of $\mathcal{C}_r(G)$, and so, $X_i \cap \mathcal{A} \neq \emptyset$ and $Y_i \cap \mathcal{A} \neq \emptyset$ by (3). Hence, it follows that the path of T between $C \in Y_1 \cap \mathcal{A}$ and $C' \in Y_2 \cap \mathcal{A}$ contains the clique C_2 , and so, C_2 hits this path. But this contradicts (*), because also $C_2 \in \mathcal{A}$.

Finally, since $\mathcal{C}_r(G)$ is a tree of diameter at most two by (5) and (6), it is necessarily a star. Moreover, no two cliques in \mathcal{A} are adjacent in $\mathcal{C}_r(G)$ by (1), and at least one endpoint of every edge of $\mathcal{C}_r(G)$ belongs to \mathcal{A} by (2) and (4). So since $|\mathcal{A}| = k > 1$, this implies that $\mathcal{C}_r(G)$ is a labeled k -star.

The proof is now complete. \square

We now discuss some consequences of the above theorem. For instance, recall the class of interval graphs. This is precisely the subclass of chordal graphs with no asteroidal triple [16]. In other words, G is an interval graph iff G is chordal and $a(G) \leq 2$. Interval graphs have been the subject of intensive study in the past, and several structural characterizations are known for the class. One of such characterizations is by minimal forbidden induced subgraphs, which consists of all cycles of length at least four and the graphs presented in the top row of Figure 6. Below them we find the reduced clique graphs of the respective graphs. Unlike this characterization, Theorem 16 provides us with a single obstruction (up to the labels of edges) that characterizes the class, a labeled 3-star. Notice that not all of the graphs in Figure 6 correspond to a 3-star, but, of course, each can be contracted to a 3-star; for instance, in the first graph we can contract the edge between the cliques $\{a, d, e\}$ and $\{a, d, f\}$ to obtain a 3-star, in the second graph we contract the three edges between $\{a, b\}$, $\{a, c\}$ and $\{a, d\}$, etc.

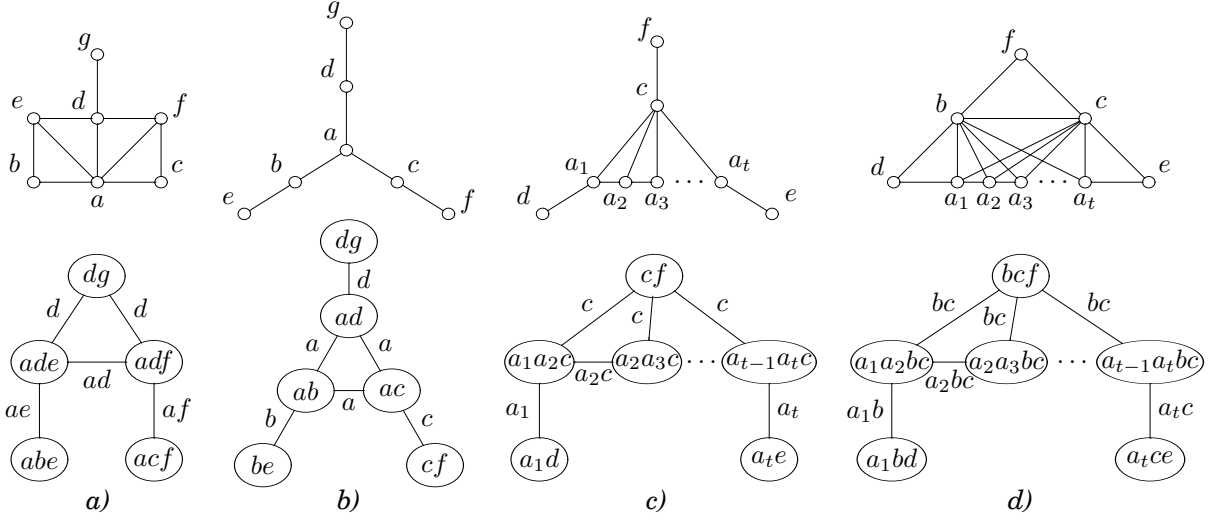

Figure 6: All chordal forbidden induced subgraphs for interval graphs and their reduced clique graphs (see [16]).

On the other hand, unlike in the case of interval graphs, not much is known about the structure of chordal graphs with bounded asteroidal number. In particular, no forbidden subgraph characterization is known, not even for small $k \geq 3$. Even if such a characterization is found, we believe that it will not likely be simple because of the many ways the paths between vertices of an asteroidal set can be arranged. Fortunately, using reduced clique graphs, one has a simple tool in the form of Theorem 16 to succinctly describe the structure of these graphs, and this is a first such characterization.

5. Leafage

In this section, we discuss a different parameter of chordal graphs, namely, the leafage. Recall that the *leafage* $l(G)$ of a connected chordal graph G is defined as the smallest integer k such that G has a tree representation, or equivalently, a clique tree with k leaves. If G is disconnected with connected components K_1, \dots, K_t , we define $l(G)$ to be the maximum among $l(G[K_1]), \dots, l(G[K_t])$.

In the following, we discuss a connection between leafage and split-minors of reduced clique graphs. Just like in the case of asteroidal sets, we need to consider a special type of permissible edges.

We say that $C_r(G')$ is a *nice split-minor* of $C_r(G)$ if $C_r(G')$ can be obtained from $C_r(G)$ by a (possibly empty) sequence of operations (L1), (L3), and the following operation:

(L2'') if e is a good and maximal edge, contract e .

Theorem 17. *If $C_r(G')$ is a nice split-minor of $C_r(G)$, then $l(G') \leq l(G)$.*

Proof. We proceed by induction. If $C_r(G')$ is obtained from $C_r(G)$ by applying the rule (L1) or (L3), then every connected component of G' is an induced subgraph of some connected component of G , and hence, it has a tree representation with at most $l(G)$ leaves. This is easily seen by considering a tree representation of the particular connected component of G with at most $l(G)$ leaves and by removing the subtrees that correspond to the vertices outside the subgraph. Hence, we conclude $l(G') \leq l(G)$.

So, we may assume that $C_r(G')$ is obtained from $C_r(G)$ using the rule (L2'') applied to a good and maximal edge $e = C_1C_2$ of $C_r(G)$. Let S denote the label of e . If G is disconnected, then $C_r(G')$ is obtained from $C_r(G)$ by contracting e in some connected component of $C_r(G)$. Recall that the leafage of G is defined as the maximum over the leafage of its connected components. This implies that it suffices to prove this case for connected graphs G .

Now, since G is connected, it has a clique tree T with $l(G)$ leaves. If T contains the edge e , then T/e is a clique tree of G' . Clearly, the number of leaves of T/e is at most the number of leaves of T , which implies $l(G') \leq l(G)$ as required. So, we may assume that T does not contain e . We show that, because e is good and maximal, we can construct a clique tree T' of G that contains e such that T'/e has at most $l(G)$ leaves. This will provide us with the same conclusion, that is, $l(G') \leq l(G)$.

Let P denote the path of T between C_1 and C_2 , and let C'_1 be the first clique on P after C_1 . Since e is not an edge of T , we have $C'_1 \neq C_2$. Also, $C'_1 \supseteq C_1 \cap C_2 = S$, because T is a clique tree. So, $C_1 \cap C'_1 \supseteq S$, and since e is maximal, we must conclude $C_1 \cap C'_1 = S$. That is, $C_1 C'_1$ is an edge of T with label S .

Suppose that C_1 is S -dominated, and let $C^{(1)}, \dots, C^{(t)}$ be the neighbours of C_1 in T other than C'_1 (possibly none). Let S_i denote the label of the edge $C_1 C^{(i)}$ for $i = 1 \dots t$. Since C_1 is S -dominated and e is maximal, we have $S_i = C_1 \cap C^{(i)} \subseteq S$. We conclude $C'_1 \cap C^{(i)} \subseteq S_i$, since T is a clique tree. We also conclude $C'_1 \cap C^{(i)} \supseteq S_i$, since $C'_1 \supseteq S \supseteq S_i$. So, Theorem 5 implies that $C'_1 C^{(i)}$ is an edge of $\mathcal{C}_r(G)$ with label S_i . Now, let T' be constructed from T by replacing the edge $C_1 C'_1$ by e , and by replacing $C_1 C^{(i)}$ by $C'_1 C^{(i)}$ for each $i = 1 \dots t$. Clearly, T' is a tree, and it is also a clique tree by Theorem 3, since it has the same weight as T . If T' has at most $l(G)$ leaves, then so does T'/e , and we are done.

So, we may assume that T' has at least $l(G) + 1$ leaves. We note that C_1 is a leaf in T' , and further, C_1 and C'_1 are the only cliques that (possibly) became leaves in T' , but were not in T . Also, C_2 is the only clique that is not a leaf in T' , but (possibly) was in T . However, if $t \geq 1$, then C'_1 is not a leaf in T' , and if $t = 0$, then C_1 is a leaf in both T and T' . In both cases, it follows that T' has exactly $l(G) + 1$ leaves, and C_2 has at least three neighbours in T' . So, since C_1 is a leaf of T' and C_2 is not a leaf in T'/e , we have that T'/e has $l(G)$ leaves as required.

We may now assume that C_1 is not S -dominated, and, by symmetry, also C_2 is not S -dominated. Since e is a good edge, every other clique is also not S -dominated. In particular, C'_1 is not S -dominated and since it is incident to the edge $C_1 C'_1$ whose label is S , there exists a clique C^* such that $C^* C'_1$ is an edge of $\mathcal{C}_r(G)$ whose label $S^* = C^* \cap C'_1$ satisfies $S^* \not\subseteq S$ and $S^* \not\supseteq S$. Let P' denote the path of T between C^* and C'_1 , and let C^{**} be the clique on P' just before C'_1 (possibly $C^{**} = C^*$).

Suppose that C^{**} also belongs to P (recall that P is the path in T between C_1 and C_2). This implies $C^{**} \supseteq C_1 \cap C_2 = S$ because T is a clique tree. So, $C^* \cap C^{**} \supseteq S$, and since e is a maximal edge, we must conclude $C^* \cap C^{**} = S$. Further, since T is a clique tree, we have $C^{**} \supseteq C^* \cap C'_1 = S^*$. This implies $S = C^* \cap C^{**} \supseteq S^*$ which contradicts the choice of C^* . Therefore, we must conclude that C^{**} is not on P , and hence, C'_1 has at least three neighbours in T . This implies that if we let T' be constructed from T by replacing the edge $C_1 C'_1$ by e , then T' is a clique tree of G , and it has at most $l(G)$ leaves, because C'_1 is not a leaf in T' . So, T'/e has at most $l(G)$ leaves as required.

That concludes the proof. \square

We remark that the above theorem does not hold for arbitrary good split-minors. For instance, consider the graph G shown at the top of Figure 4c where $\mathcal{C}_r(G)$ is the graph at the bottom of Figure 4c. The graph G has a clique tree with four leaves as indicated by thick edges in $\mathcal{C}_r(G)$. Further, the edge between cliques $\{a, f\}$ and $\{a, g\}$ is good because no clique is $\{a\}$ -dominated, but it is not maximal. Contracting this edge yields a graph G' depicted with its reduced clique graph in Figure 4d. The graph G' , however, does not have a clique tree with four leaves. (The thick edges in $\mathcal{C}_r(G')$ show a sample clique tree with 5 leaves.) This is because every clique tree of G' has leaves $\{n, f\}$, $\{g, o\}$, $\{b, j\}$, and $\{c, k\}$, but also one of $\{b, d, l\}$, $\{c, e, m\}$, $\{a, b, h\}$, and $\{a, c, i\}$ is a leaf. A similar situation occurs in Figure 4a where the edge between cliques $\{a, b, c\}$ and $\{b, c, d\}$ is maximal but not good, since the clique $\{b, c, g\}$ is $\{b, c\}$ -dominated but neither $\{a, b, c\}$ nor $\{b, c, d\}$ is. Clearly, $l(G) \leq 3$ as demonstrated by the thick edges of $\mathcal{C}_r(G)$. After contraction, we obtain G' shown in Figure 4b, and $l(G') = 4$ because $\{a, c, h\}$, $\{d, i\}$, $\{b, f\}$, and at least one of $\{a, b, e\}$, $\{b, c, g\}$ are leaves in every clique tree of G' .

Now, just like in the case of asteroidal number, Theorem 17 allows us to define minimal forbidden split-minors for the leafage; this time, of course, with respect to the notion of a nice split-minor. For instance, if G is a graph such that $\mathcal{C}_r(G)$ is a labeled k -star (e.g., Figure 5ab), then $T = \mathcal{C}_r(G)$ is the unique clique tree of G , and hence, $l(G) = k$. However, any contraction or split (edge) removal results

in a forest whose connected components have at most $k - 1$ leaves. So, any labeled k -star is a minimal forbidden split-minor for leafage $k - 1$. For leafage two, we have $a(G) = l(G)$, since this case again coincides with interval graphs, and hence, we can conclude $l(G) = 2$ if and only if no labeled 3-star is a nice split-minor of $C_r(G)$. (This follows from the proof of Theorem 16 in which we always contract only maximal edges.) For larger values of leafage, there are other examples. For instance, consider the graph G depicted in Figure 5c. The corresponding reduced clique graph $C_r(G)$ is shown in Figure 5d. It can be easily verified that $a(G) = 3$ and $l(G) = 4$. However, removing any permissible split or contracting any permissible edge yields a graph G' with $l(G') = 3$. This shows that $C_r(G)$ is a minimal forbidden split-minor for leafage 3 that is not a labeled 4-star. In fact, using this example, one can construct examples of minimal forbidden split-minors different from labeled k -stars also for any other value of leafage. Unfortunately, we do not know whether this way we construct all minimal forbidden split-minors for leafage, and so we do not have a theorem for leafage similar to Theorem 16.

Finally, we note that, since the edge considered in the proof of Theorem 15 is maximal, we immediately have the following observation.

Theorem 18. *Every reduced clique graph is totally decomposable by the rules (L1) and (L2'').*

Acknowledgements

The authors would like to thank the anonymous referees for their comments and useful suggestions which helped to improve the presentation of this paper.

References

- [1] BROERSMA, H., KLOKS, T., KRATSCH, D., AND MÜLLER, H. Independent sets in asteroidal triple-free graphs. *SIAM Journal on Discrete Mathematics* 12 (1999), 276–287.
- [2] BUNEMAN, P. A characterization of rigid circuit graphs. *Discrete Mathematics* 9 (1974), 205–212.
- [3] CUNNINGHAM, W. H. Decomposition of directed graphs. *SIAM J. on Algebraic and Discrete Methods* 3 (1982), 214–228.
- [4] FULKERSON, D. R., AND GROSS, O. A. Incidence matrices and interval graphs. *Pacific Journal of Mathematics* 15 (1965), 835–855.
- [5] GALINIER, P., HABIB, M., AND PAUL, C. Chordal graphs and their clique graphs. In *Graph-Theoretic Concepts in Computer Science (WG'95), Lecture Notes in Computer Science 1017* (1995), Springer-Verlag, pp. 358–371.
- [6] GAVRIL, F. The intersection graphs of subtrees in trees are exactly the chordal graphs. *Journal of Combinatorial Theory B* 16 (1974), 47–56.
- [7] GAVRIL, F. Generating the maximum spanning trees of a weighted graph. *Journal of Algorithms* 8 (1987), 592–597.
- [8] GOLUMBIC, M. C. *Algorithmic Graph Theory and Perfect Graphs (2nd edition)*. North Holland, 2004.
- [9] HABIB, M., AND LIMOUZY, V. On some simplicial elimination schemes for chordal graphs. In: *DIMAP Workshop on Algorithmic Graph Theory, Electronic Notes in Discrete Mathematics* 32 (2009), 125–132.
- [10] HABIB, M., AND STACHO, J. A decomposition theorem for chordal graphs and its applications. In: *European Conference on Combinatorics, Graph Theory and Applications (EuroComb 2009), Electronic Notes in Discrete Mathematics* 34 (2009), 561–565.
- [11] HABIB, M., AND STACHO, J. Polynomial-time algorithm for the leafage of chordal graphs. In *Algorithms - ESA 2009, Lecture Notes in Computer Science 5757* (2009), Springer Berlin/Heidelberg, pp. 290–300.
- [12] KLEINBERG, J., AND TARDOS, E. *Algorithm Design*. Pearson Education, Inc., New York, 2006.
- [13] KLOKS, T., KRATSCH, D., AND MÜLLER, H. Asteroidal sets in graphs. In *Graph-Theoretic Concepts in Computer Science (WG'97), Lecture Notes in Computer Science 1335* (1997), Springer Berlin/Heidelberg, pp. 229–241.
- [14] KRATSCH, D., AND STEWART, L. Approximating bandwidth by mixing layouts of interval graphs. *SIAM Journal on Discrete Mathematics* 15 (2002), 435–449.
- [15] KRUSKAL, J. On the shortest spanning subtree of a graph and the traveling salesman problem. *Proceedings of the American Mathematical Society* 7 (1956), 48–50.
- [16] LEKKERKERKER, C. G., AND BOLAND, J. C. Representation of a finite graph by a set of intervals on the real line. *Fundamenta Mathematicae* 51 (1962), 45–64.
- [17] LÉVEQUE, B., MAFFRAY, F., AND PREISSMANN, M. Characterizing path graphs by forbidden induced subgraphs. *Journal of Graph Theory* 62 (2009), 369–384.
- [18] MA, T. H., AND SPINRAD, J. An $O(n^2)$ algorithm for undirected split decomposition. *Journal of Algorithms* 16 (1994), 145–160.
- [19] MATSUI, Y., UEHARA, R., AND UNO, T. Enumeration of the perfect sequences of a chordal graph. *Theoretical Computer Science* 411 (2010), 3635–3641.
- [20] MCKEE, T. A. Minimal weak separators of chordal graphs. *Ars Combinatoria* (2011). to appear.

- [21] PAUL, C., AND TELLE, J. A. Branchwidth of chordal graphs. *Discrete Applied Mathematics* 157 (2009), 2718–2725.
- [22] SHIBATA, Y. On the tree representation of chordal graphs. *Journal of Graph Theory* 12 (1988), 421–428.
- [23] WEST, D. B. *Introduction to Graph Theory (2nd edition)*. Prentice Hall, 2000.