

Collaborative Social Modeling for Designing a Patient Wellness Tracking System in a Nurse-Managed Health Care Center

Yuan An

iSchool at Drexel University
Philadelphia, USA

yan@ischool.drexel.edu

Prudence W. Dalrymple

Institute for Healthcare Informatics
iSchool at Drexel, Philadelphia, USA

pdalrymple@ischool.drexel.edu

Michelle Rogers

iSchool at Drexel
Philadelphia, USA

mrogers@ischool.drexel.edu

Patricia Gerrity

College of Nursing and Health
Professions
Drexel University, Philadelphia, USA
pg28@drexel.edu

Jennifer Horkoff

Department of Computer Science
University of Toronto, Canada

jenhork@cs.toronto.edu

Eric Yu

Faculty of Information
University of Toronto, Canada
yu@ischool.utoronto.ca

ABSTRACT

There has been an increasing need for developing health information systems for improving clinical processes and outcomes. Deeply understanding and accurately capturing the information needs of the stakeholders is crucial to successfully designing and deploying such a system. Empirical study on “effective” methodologies for requirements analysis for information system design is one of the important aspects in design science research in information systems. In this paper, we present our case study on exploring a goal-oriented requirements analysis technique called the *i** framework for eliciting and modeling the requirements for a patient wellness tracking (PWT) system in a nurse-managed health care services center. The center employs a transdisciplinary care approach for managing illnesses. The innovation and complexity in the health care approach brings about many challenges in designing a PWT system that always provides positive impacts on the current workflows at the center. The system is aimed to maintain information about a wide variety of health and wellness services provided to patients. We want to thoroughly elicit the requirements through modeling the socio-technical environment and analyzing the goals of stakeholders through a collaborative approach. For this purpose, we explored the *i** framework and introduced two adaptations in order to meet our needs in eliciting and capturing requirements. Our preliminary experience in this case study demonstrates that using the *i** approach with our adaptations is a potentially effective method for eliciting, modeling, capturing, and validating the requirements

of healthcare information systems.

Categories and Subject Descriptors

D.2.1 [Software]: Software Engineering – *requirements/specifications – elicitation methods.*

General Terms

Management, Documentation, Design, Human Factors

Keywords

Health Care Information Systems; Requirements Analysis; System Design; Goal-Oriented Analysis; Social Modeling

1. INTRODUCTION

Health information technology (health IT) aims to use information and communication technology in health care to support the delivery of health care to patients or to support patient self-management [2, 5, 11]. Health IT has been demonstrated to improve healthcare outcomes in various healthcare settings [1, 12, 13]. Current examples of health IT applications include electronic medical records (EMR), personal health records (PHR), clinical alerts and reminders, computerized clinical decision support systems, and many others. With the great advance in information and communication technologies, developing health IT systems to support effective and efficient management of chronic diseases has become an interesting and challenging problem in both the healthcare and information technology fields.

Deeply understanding and accurately capturing the information needs of the stakeholders is crucial to successfully designing and deploying such a system. Empirical study on “effective” methodologies for requirements analysis for information system design is one of the important aspects in design science research in information systems. In this paper, we present our study on exploring a goal-oriented requirements analysis technique called the *i** framework for eliciting and modeling the requirements for a

Permission to make digital or hard copies of all or part of this work for personal or classroom use is granted without fee provided that copies are not made or distributed for profit or commercial advantage and that copies bear this notice and the full citation on the first page. To copy otherwise, or republish, to post on servers or to redistribute to lists, requires prior specific permission and/or a fee.

DESRIST'09, May 7–8, 2009, Malvern, PA, USA.

Copyright 2009 ACM 978-1-60558-408-9/09/05...\$5.00.

patient wellness tracking (PWT) system in a nurse-managed healthcare services center (hereafter, the center) in an urban area. The patient wellness tracking (PWT) system is aimed at maintaining information about a wide variety of health and wellness services provided to patients with various illnesses including chronic diseases. These services include physical exams, diagnosis and treatment of illness, family planning, health maintenance/disease prevention services, behavioral health services, physical fitness programs, dental services, nutrition services, and adolescent health initiatives. In particular, the center employs an innovative and transdisciplinary model of care that combines both medical and behavioral health services. This combination of behavioral health and primary care strengthens the services provided to patients by placing a primary behavioral health specialist and social worker directly in primary care. Both of these services are fully integrated into primary care to form a team approach to coordinated and seamless care.

The innovation and complexity in the health care approach at the center brings about many difficulties in adopting health IT. While the center offers area residents a centralized location to receive health and wellness services, the care providers in the transdisciplinary team need effective and efficient ways for exchanging patient health information and making clinical decisions. Information technology has the potential to meet the goal. However, many commercial health IT products and off-the-shelf components are not designed incorporating the transdisciplinary model. As a result, a health IT system could easily become a simple data storage-and-retrieval tool.

A PWT system should be able to provide support for clinical decision making and identify noncompliant patients who require health care resources for more intensive management. Designing and developing such an automated system requires a deep understanding of the medical care process and correctly capturing the needed information in a computer system. Although there has been much research on developing electronic medical record (EMR) systems in hospitals and clinics for various purposes [6, 9, 13, 15, 20], there is little study on designing comprehensive healthcare information systems that can effectively track and maintain a holistic and transdisciplinary view of patient wellness information, especially, for managing diseases at nurse-managed community healthcare services centers.

There are a number of challenges in the process of eliciting and modeling the requirements for designing the PWT system for the center. In section 2, we will describe the background information in more detail. Here we summarize some of the challenges as follows.

First, the transdisciplinary approach for managing and treating illnesses is a very complex healthcare process involving a group of professionals in different disciplines. These professionals are trained to focus on special areas. It is challenging for a system analyst or designer without healthcare background to fully understand the healthcare process and to design a system to facilitate the workflow between different professionals.

Second, although the health care providers in the care team for managing and treating a specific illness know what the procedure is, some of the information they routinely process have become

tacit and hidden knowledge. It is challenging to elicit the complete requirements from the care providers in designing the PWT system.

Third, system analysts and designers tend to use technical diagrams and models to represent the requirements and some initial design. Healthcare professionals often do not easily grasp the semantics of the software design diagrams. As a result, feedback from stakeholders is insufficient.

Fourth, medical and healthcare lingo often presents a tremendous barrier for system analysts to capture the requirements. In the requirements analysis process, system analysts seek to answer a list of “why” questions. This helps analysts choose the best alternatives to meet the system functionality. In designing health IT systems, comprehending medical and healthcare lingo poses significant challenges to information technology professionals. Communication between stakeholders and system analysts is difficult, especially at the initial stage of the design process.

Finally, it is challenging to evaluate the stakeholders’ opinions on the results of the design and development. Unlike business activities where productivity and profit would be good measurements for success, healthcare services focus on patient safety and quality of health care. A health IT system must be designed to provide positive effects on current workflows of health care providers.

Through empirical study, we can advance our knowledge on “effective” methodologies for requirements analysis for information systems design. In this paper, we explore a goal-oriented analysis technique called the i^* framework [29] for overcoming some of the challenges in eliciting and modeling the requirements for the PWT system at the center. One of the main features in this study is to conduct collaborative activities for requirements elicitation, modeling, and validation. Use of the i^* technique comes through a gradual learning process. Initially, to understand the needs of the center, we conducted a series of focus group meetings with the staff at the center without using i^* for almost one year. Due to the challenges we mentioned above, we made little progress in capturing the requirements of the PWT system. Consequently, we needed a method that could facilitate communication between stakeholders and system analysts. Immediate tasks include analyzing the socio-technical environment at the center, capturing the workflow of the health care model, and identifying the problems that need a health IT solution.

In recent years, requirements engineers and researchers have proposed to separate the requirements analysis process into two phases: an early requirements analysis phase and a later requirements analysis phase [17, 19, 23, 31]. Traditionally, requirements engineering has focused on the so-called later phase requirements engineering. Specifically, requirements engineering began with a set of statements expressing stakeholders’ wishes about what the system should do. Software designers and engineers would apply a set of techniques to refine the often incomplete, inconsistent, and ambiguous statements into graphical models using boxes and arrows or logical formalisms [25]. The goal of this later phase requirements engineering is to specify the functionality of the system in detail so that the developers can begin to implement the system.

On the other hand, early phase requirements engineering is concerned with analyzing the goals of the organizations and stakeholders in order to accurately capture user's requirements. The system analysts at this stage consider how the intended system could best meet the goals. The emphasis here is a list of "why" questions that underlie the system requirements, rather than the detailed specification of the system design. In addition, the early phase requirements also emphasize the involvement of the stakeholders in the system design process. For designing the PWT system for the center, we realized that almost all of the challenges we encountered are related to the early phase of requirements analysis. To increase the chance of successfully developing and deploying a PWT system, we needed to conduct a thorough early requirements analysis and draw useful conclusions. In this paper, we report on our effort including the adoption and adaptation of the i* framework.

The choice of the i* approach is based on several considerations. First, the i* approach focuses on the early requirements analysis phase during the process of software development. It helps the system analysts to deeply understand the domain and the problems. Second, the i* approach focuses on eliciting the goals of stakeholders. It encourages the involvement of the stakeholders in the requirements analysis process, and helps the stakeholders understand the limitations and potentials of adopting technical systems. Third, a typical i* approach uses visual notations to express various intentional elements involved in a system such as goals, tasks, resources, and dependencies. It facilitates the communications between stakeholders and system analysts. Finally, the i* approach has been successfully applied to many other domains for early requirements analysis [3, 14, 30].

The central elements in i* models are intentional actors. An actor is an autonomous agent that can fulfill some goals by performing some tasks using some resources. Actors depend on each other to achieve their goals and influence the world. A typical process for requirements analysis using i* develops two types of models: *strategic dependency (SD)* graphs and *strategic rationale (SR)* graphs. A SD graph describes the dependency relationships between different actors, while a SR graph looks into the internal intentional relationships of an actor. Each type of model uses a set of designated visual notations for modeling purpose. A detailed introduction to the i* framework will be presented in section 3.

The analysis of the requirements for designing the PWT system is an iterative process consisting of several critical steps as illustrated in Figure 1. The first step is to identify the stakeholders and the users who are going to use the system. The second major step is to produce the strategic dependency (SD) models. To engage the stakeholders and users in this modeling process, we use a simplified dependency model for the healthcare providers to express their dependencies. Third, system analysts convert the simplified dependency graphs into i* SD models for formal analysis. If analysts are not satisfied with the understanding of the dependencies between different actors, they will go back to talk to the stakeholders for more requirements elicitation.

Subsequently, the analysts and the stakeholders will work together in decomposing high-level goals and tasks into lower-level and more concrete goals and tasks. Next, strategic rationale models will be generated and alternative design choices will be explored through a qualitative reasoning process on goals and other system qualities (referred to as *softgoals* in the i*

framework). Until a final system design is accepted by both stakeholders and designers, there will be a number of iterations involving many collaborative activities. Figure 1 outlines only the major steps and iterations.

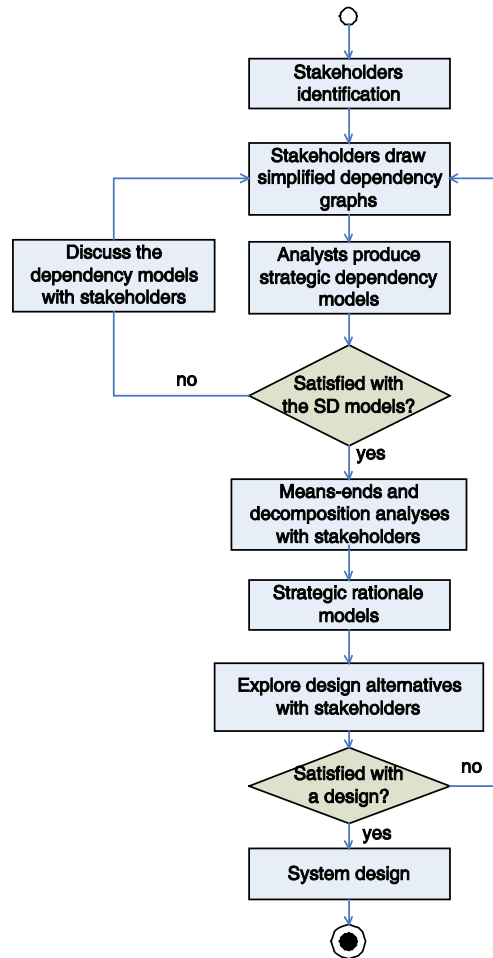

Figure 1: A Design Procedure

In the rest of the paper, we present the results of using the i* framework for eliciting and modeling the requirements of the PWT system. Our major contributions in this case study include 1) a methodology including adaptations for applying the i* framework in eliciting and modeling the requirements for a comprehensive healthcare information system for managing and treating illnesses and 2) the design artifacts that describe the components the intended system should contain in order to fulfill the health care goals.

We also report on our preliminary experience of the exploratory study on using the i* framework for collaborative social modeling. Our experience showed that the i* framework with the adaptations is an effective tool. In particular, it can facilitate communication between health care providers and system analysts, increase the involvement of stakeholders in the system design process, improve system analysts' understanding on the critical issues of disease management, and help the stakeholders validate the captured requirements. However, our experience also showed that expressing the intentional elements in terms of goals, resources, tasks, and softgoals is often confusing for a novice. It is

not easy to use i^* models for expressing a sequence of activities. The order of tasks cannot be expressed in the i^* models. Moreover, the formal goal refinement process is too time-consuming and technical-intensive for non-technical stakeholders. There is a lack of a systematic and effective way for eliciting refined goals to generate strategic rationale models.

The remainder of the paper is organized as follows. Section 2 discusses the background of the center and the chronic care approach for chronic disease management. Section 3 describes the notations used in the i^* framework. Section 4 presents our design methodology and resultant artifacts. Section 5 draws some useful experience and observations from the study. Section 6 discusses some related work. Finally, section 7 presents future directions and concludes this paper.

2. THE TRANSDISCIPLINARY CARE APPROACH FOR CHRONIC DISEASE MANAGEMENT AT THE CENTER

The healthcare center where the intended system is designed for is a nurse-managed community health services facility. The center is located in an urban area with a low-income and medically underserved population. The center offers the area residents a centralized location to receive health and wellness services. It uses a transdisciplinary and holistic approach to chronic care that has the potential to affect the quality of life in the population. This holistic approach has been specifically developed for delivery by nurse practitioners and other allied health practitioners in a primary care setting.

Figure¹ 2 shows the chronic care model [27] used in the transdisciplinary approach. The care model is a conceptual framework integrating transdisciplinary services for chronic disease care. It describes six key components for managing patient with a chronic disease: *clinical information systems, decision support, delivery system design, self-management support, health care organization, and community resources*. The key ingredients of the model are *disease prevention, longitudinal care, and coordinating patient care*. The chronic care model relies on advanced information technology as a critical support for coordinating a variety of services provided by a group of healthcare professionals.

2.1 Transdisciplinary Care Team

In the core of the chronic care model, health professionals work as a team. As mentioned, this team offers patients healthy living programs including a wide variety of health and wellness services. Referrals are made for any additional services that might be needed, such as physical therapy.

For designing the PWT system that supports the team members in carrying out the coordinating functionality of the chronic care model, system analysts must identify the key stakeholders that may be affected by the system. Patients are the most important member of the health care team. After all, patients are the ones who are affected by diseases and who care for it every day. At the

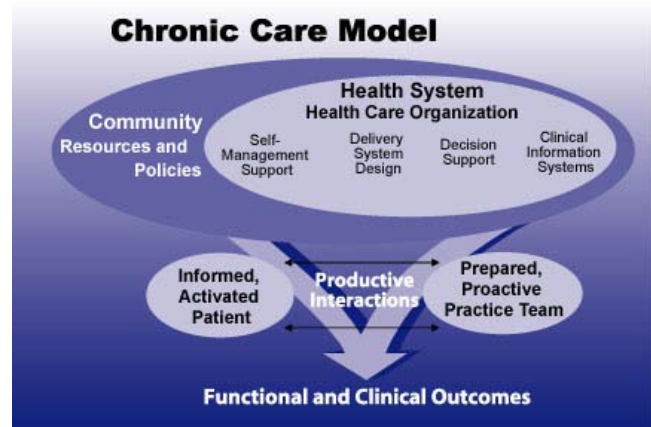

Figure 2: Chronic Care Model

provider side, the core care team includes a nurse practitioner, behavioral health specialist, and social worker. This arrangement allows providers to integrate behavioral health services directly into primary care. Nurse practitioners focus on health maintenance, disease prevention/screening/treatment, and patient education. The primary behavioral health specialist focuses on mental health issues (including any issue that might affect a patient's health status, e.g., emotional health and quality of life), whereas the social worker identifies any social and support services patients may need. Patients are also referred to health educators, nutritionists, physical therapists, and dentists as necessary.

2.2 System Objectives

Currently, data about patients who participate in the healthy living programs and accept wellness services is collected manually at the center. However, the center has implemented an EMR system for managing clinical data. Consequently, the information about patients' health status is stored in fragmented places hindering efficient patient tracking and outcome evaluation. The center expects that an electronic patient wellness tracking (PWT) system would enable the center to link the success of the health education and chronic disease management programs to clinical data. Designing such a PWT system that meets the needs of the center is the main theme of this research.

3. THE i^* FRAMEWORK FOR SOCIAL MODELING

i^* is a goal-oriented requirements modeling approach. It focuses on the interactions and dependency relationships among autonomous agents and their surrounding environment. Traditionally, system analysts and designers have focused on information content and processes that are to be embedded in automated systems. It has been increasingly realized that it is equally important to analyze and model the social context and surrounding environment of systems so that the right system would be built. Moreover, capturing the social context and surrounding environment in system design and modeling enhances the system's ability to better deal with the changing needs of stakeholders.

As illustrated in Figure 2 and described in Section 2, a clinical information system is embedded in a health care organization

¹ The picture is adopted from http://www.drugabuse.gov/NIDA_notes/NNV0118N3/Discovering.html

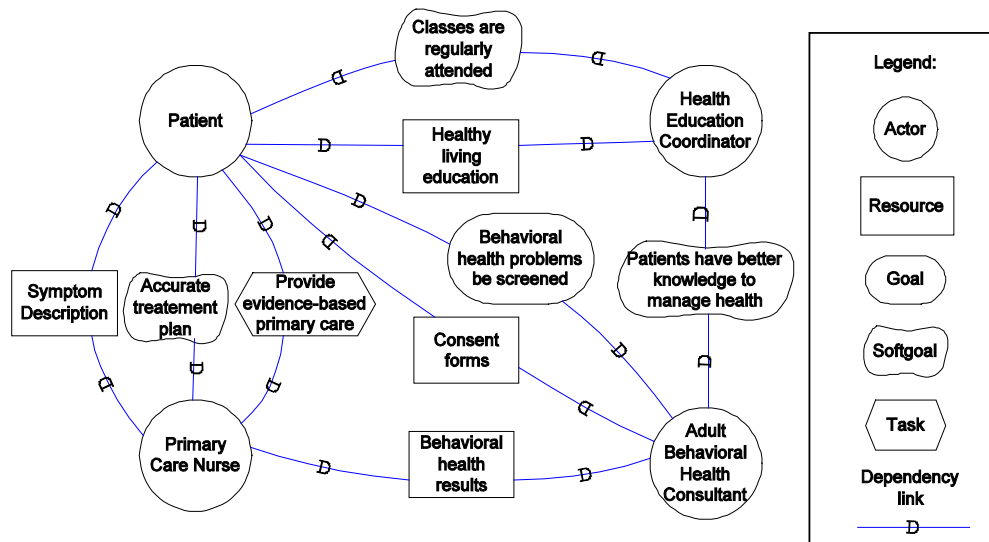

Figure 3: A Strategic Dependency Model

which in turn is part of broad community resources serving the residents. It is important to analyze and model the dependency relationships and information flows between the information system and other critical components in order to build the right health IT system. In the *i** framework, both the context and the system are modeled as a set of agents/actors. The socio-technical environment is characterized by the relationships among agents at an intentional level in terms of what each agent wants, and how the intents might be satisfied, possibly through other agents. This abstraction is useful for the strategic reasoning on exploring what system to be built.

As mentioned, the *i** framework consists of two kinds of models. The first is the *strategic dependency* (SD) model and the second is the *strategic rationale* (SR) model. Both models describe networks of intentional relationships. In SD models, actors are related to each other through intentional dependencies. The underlying concepts for dependencies include goals, abilities, commitments, beliefs, and so on. In an SR model, an actor is examined in more detail in terms of achieving its goals. The underlying reasoning process relies on means-ends analysis and task decomposition.

3.1 The Strategic Dependency Model

Figure 3 shows an example of a strategic dependency (SD) model for the healthcare services center. In such a setting, a Patient depends on a Primary Care Nurse to provide primary care in order to improve his/her health. The Primary Care Nurse depends on the Patient to provide accurate description about his/her symptoms. The model also describes many other dependency relationships among Patient, Health Education Coordinator, Adult Behavioral Health Consultant, and Primary Care Nurse.

Specifically, a Strategic Dependency (SD) model is a graph which consists of a set of nodes and links. A node represents an actor, and a link between two actors indicates that one actor depends on the other for something in order that the former may fulfill some goal. The depending actor is called the *depender*, while the actor

who is depended upon is called the *dependee*. The object attached to the dependency relationship is called the *dependum*. When the depender depends on dependee for a dependum, the depender is able to achieve goals that it was not able to without the dependency, or not as easily or as well. If the dependee fails to deliver the dependum, the depender would be adversely affected in its ability to achieve its goals.

There are four types of dependencies that can be specified in a SD model. In a *task dependency*, the depender depends on the dependee to perform some activity. For example, the Patient depends on the Primary Care Nurse to Provide evidence-based primary care. In a *goal dependency*, the depender depends on the dependee to achieve a goal with a means chosen by the dependee. For example, the Patient depends on the Adult Behavioral Health Consultant to fulfill the goal of screening behavioral health problems (Behavioral health problems be screened). In a *resource dependency*, the depender depends on the dependee to provide some resources. For example, the Primary Care Nurse depends on the Patient to describe their symptoms (Symptom description). Finally, in a *softgoal dependency*, the depender depends on the dependee to achieve a softgoal, which indicates that there are no *a priori*, cut-and-dry criteria for what constitutes meeting the goal. For example, the Patient wants to have an Accurate treatment plan provided by the Primary Care Nurse.

While patient care is often considered in terms of sequences of events and actions, SD model focuses on the dependency relationships between different actors. In early requirements analysis phases, the goal is to understand the information needs of the stakeholders in terms of intentional elements. Some relationships do not have directly associated actions. For example, the Adult Behavioral Health Consultant depends on the Health Education Coordinator to improve patients' awareness and knowledge about managing their health (Patients have better knowledge to manage health). This relationship represents a soft goal dependency between the two

actors. The relationship requires further analysis for fulfillment of the goal.

3.2 The Strategic Rationale Model

The strategic rationale (SR) model provides a more detailed level of modeling by looking inside actors to model internal intentional relationships. Intentional elements (goals, tasks, resources, and softgoals) appear in SR models not only as external dependencies, but also as internal elements arranged into hierarchical structures of means-ends, decompositions, and contribution relationships.

Figure 4 shows an SR model that elaborates on the rationale of a primary care nurse at the health services center. The gray area indicates that the elaboration is inside the Primary Care Nurse actor. The circle line around the gray area draws the boundary of the actor. For elaboration, there are several types of relationships between the intentional elements at different levels: (1) a means-ends link identifies a task (means) for fulfilling a goal (end); (2) task decomposition links identify a set of sub-tasks for performing a high-level task; (3) a contribution link shows a contribution toward satisfying a softgoal; and (4) the goal decomposition links refine high-level abstract goals into lower-level more concrete ones. An and-decomposition indicates the “and” relationship among subgoals, while an or-decomposition indicates the “or” relationship among subgoals.

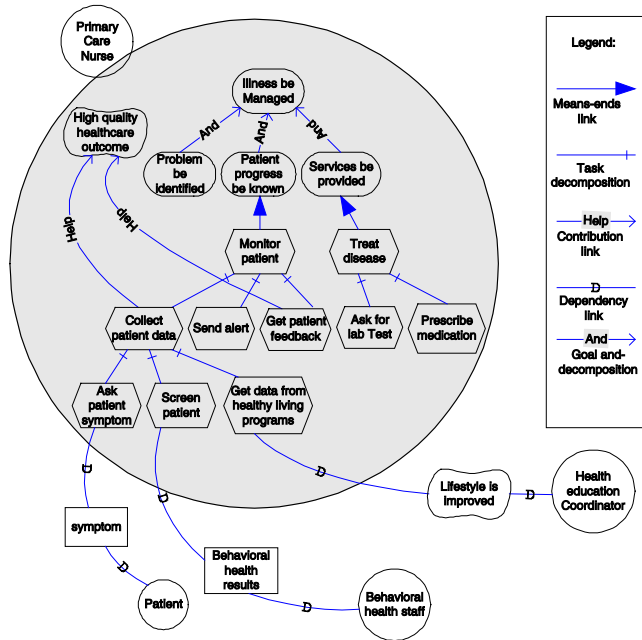

Figure 4: A Strategic Rationale Model

We can see that the goal of the nurse is to manage illness, which can be refined into three subgoals with an “and” relationship: identifying the problems (Problem be identified), knowing patient progress (Patient progress be known), and providing services (Services be provided). The goal “Patient progress be known” can be met by monitoring patient, while the goal “Services be provided” can be met by treating disease. The task of monitoring patient is decomposed into three sub-tasks: collecting patient data, sending automatic alerts, and obtaining patient feedback. To collect patient data, three sub-tasks have been identified: asking patient symptoms,

screening patient, and obtaining input from the healthy living programs. Each of the three sub-tasks depends on some other actors to commit something.

Since a soft goal represents something that cannot be met in a clear-cut fashion, positive or negative contribution links are used in an SR model. For example, there is a positive contribution link (“Help”) from the sub-goal “Get patient feedback” to the softgoal “High quality health care outcome”. The positive contribution link indicates that the achievement of the goal of “getting patient feedback” will contribute positively but not sufficiently to fulfill the goal of “High quality health care outcome” for the nurse at the center. There are other types of contribute links which will be used and explained in later sections.

4. DESIGNING A PWT INFORMATION SYSTEM TO SUPPORT THE TRANSDISCIPLINARY CARE AT THE CENTER

4.1 An Initial Attempt

At the beginning, the center expressed their expectation for an information system to “reduce the amount of paper work in the current work flow of patient care.” When this goal was presented to our team which consists of experts in information science and technology, we started to investigate the organizational structure, healthcare activities, and existing technological systems for meeting the goals. We found that in such a typical healthcare setting, there are several barriers in adopting information technology. Some barriers include lack of staff training for the existing EMR system, lack of communication between IT personnel and users, unawareness of functionality, and limited computer literacy among patients. Our initial findings led us to the tasks of training the staff on the current EMR system and seeking a solution to automatically exchanging data with other EMR systems used by other healthcare partners. We didn’t realize that there were two problem associated with our initial endeavor. First, we didn’t realize that the current EMR system that was implemented by the center was mainly designed for physician’s view of patient care. Although the EMR was purchased from a mainstream brand and works well for managing clinical data in hospitals and clinics, it was not designed from nurse’s perspective in a community health services center, especially, for chronic disease care using the transdisciplinary approach. Data on behavioral health issues and wellness was not captured and linked to the clinical data in the EMR system. Second, the initial goal for “reducing paper work in patient care” was somewhat misleading when the center expressed their expectation for an information system. As noted, a health care team in the transdisciplinary approach consists of professionals in different disciplines. Increasing the efficiency and effectiveness of communications among team members is an obvious requirement for using an information system. However, simply introducing an information management system would not always increase the efficiency and effectiveness of communication among its users. “Reducing paper work” is not always equivalent to efficient communications. There is something more profound in the information needs for patient care process.

These two problems indicate that (1) we did not fully understand the information needs of the providers involved in the transdisciplinary care approach and (2) we had not identified the

root causes of the communication problems among providers and patients. To tackle the problems, we decide to explore the goal-oriented requirements analysis technique, the *i** framework.

4.2 Stakeholders Identification

The first step of applying *i** for requirements analysis is to identify potential actors/stakeholders of the application domain.

In Section 2, we described the transdisciplinary care approach at the center. From the description, we can identify at least the following intentional actors: Patient, Nurse Practitioner, Behavioral Health Specialist, and Social Worker. In order to identify all potential actors/stakeholders that are involved in the social context of the transdisciplinary care approach, we held several group meetings with the staff at the center. In addition, we observed the providers' activities and workflows in dealing with patients, communicating with co-workers, and using the EMR systems. From these meetings and observations, we recognized that there was a list of individuals who directly or indirectly interacted with the care process for a patient. We identify these individuals as intentional actors in the *i** analysis. Our later collaborative modeling processes will further confirm their participations in the social context of the transdisciplinary care approach. The actors in this list are Wellness Coordinator (WC), Health Education Coordinator (HEC), Director, Nurse Administrator, Clinical Nurse (CN), Primary Care Nurse (PCN), Public Health Nurse (PHN), Front Desk (Receptionist), Nurse Family Partnership (NFP), Physical Therapy (PT), Dentist, Psychiatrists, Midwives, and Other Contractors.

Although we have identified a list of potential actors in the subject domain, we still do not know what the health care activities are for these individuals and what information they need to process for providing their respective services. To answer these questions, we begin with eliciting stakeholders' information needs.

4.3 Eliciting Stakeholders Information Needs Using a Simplified Dependency Model

Requirements engineering practice has suggested a set of techniques for eliciting requirements from stakeholders including introspection, background reading, analyzing hard data interviews, requirements workshop, brainstorming, and storyboarding [24]. In the process of exploring the *i** framework for eliciting requirements for the PWT system, we notice that the normal *i** notation is too complicated for a layperson to comprehend. In order to actively engage the stakeholders in the modeling process, our *first adaptation* is to use a simplified dependency graph for the staff at the center to express the intentional dependency relationships among them.

The simplified dependency graph only uses circles for actors and lines for relationships between actors. We asked each staff member involved in the transdisciplinary care approach to draw a relationship diagram centered on her role in the approach. This process helped the staff express the requirements and model the social context for each of them. Consequently, everybody was able to express some thoughts using the diagrammatic tool. The sizes of the simplified dependency graphs range from 7 to 15 nodes connected by 9 to 52 links. That tells us that staff may

interact with 7-15 other individuals or agents in her social context through 9-52 various relationships for achieving her professional goals. After we collected these diagrams produced by the staff, we moved to the next step to model the socio-technical environment in a more formal way using the *i** framework. The entire modeling process was carried out collaboratively between the system analysts and the stakeholders. Specifically, we checked the SD models generated by the system analysts with the stakeholders and modified the models accordingly.

4.4 Modeling the Socio-Technical Environment Using *i**

Figure 5 provides an example SD model showing some key relationships between Patient and Nurse Practitioner at the center. The SD model also contains some elaboration on the actors involved in the dependency relationships. Nurse Practitioner provides services on disease prevention, disease screening, and disease treatment. These are the tasks the Patient depends on in order to obtain medical treatment. Patients have the goal to control chronic illness. This goal is decomposed into two sub goals: Illness be self managed and Medical treatment be obtained.

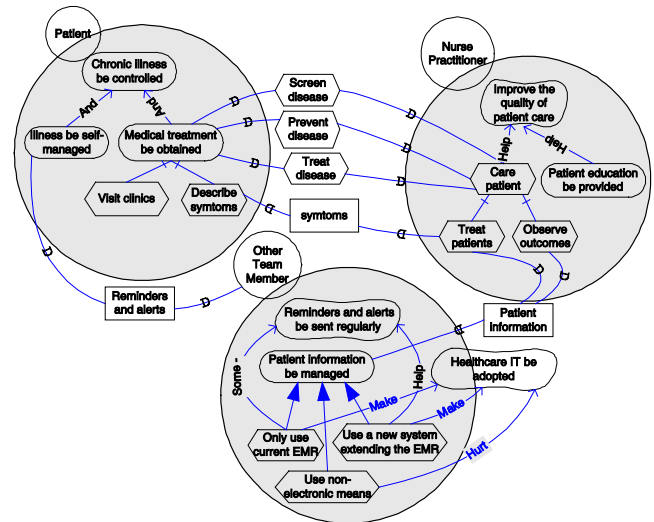

Figure 5: Intentional Relationships among Patient, Nurse Practitioner, and Other Team Member

To obtain medical treatment, the patient must Visit clinics and Describe symptoms. Nurse practitioners want to Improve the quality of patient care. This softgoal is affected by achieving the goal Patient education be provided and performing the task Care patient. In the model, the link "Help" indicates that the accomplishment of the sub-tasks/goals contributes positively to the softgoal Improve the quality of patient care. There are two sub tasks for Nurse Practitioner to Care patient: Treat patient and Observe outcomes. Both sub tasks depend on the resource Patient information provided by some Other Team Members. Each team member is an intentional actor with the goal of managing patient information. This end can be met by the means Only use current EMR system, Use non-electronic means, or Use new information system extending the EMR. The other team members want to adopt health IT for

information management. The task Use non-electronic means contributes negatively (“Hurt”) to the softgoal, while the other two tasks Only use current EMR and Use a new system extending the EMR contribute positively (“Make”) to the softgoal.

One of the softgoals for a team member is to send reminders and alerts regularly. Through interviewing the staff at the center and observing their information processing activities, we discovered that the current EMR system does not have an easy way for a user to generate a reminder or an alert to a patient. Therefore, we add two contribution links in the model: a negative contribution link “Some-” from the task Only use current EMR system to the softgoal Reminders and alerts be sent regularly and positive link “Help” from the task Use new information system extending the EMR to the same softgoal. Patients depend on the reminds and alerts sent by the team members for self-managing chronic illness.

The model illustrates the qualitative reasoning capabilities of the i* framework for decision making among design alternatives. System analysts can carry out the qualitative reasoning process interactively to evaluate whether an intentional element (goal, task, resource, or soft goal) is viable or not. For a softgoal, viability means whether it is sufficiently met. The qualitative reasoning process is done through a labeling algorithm on the SR graphs. The algorithm propagates a series of labels on the contribution links through the graphs. The propagation depends on the type of link. For example, the positive contribution link types for softgoals are Help (positive but not by itself sufficient to meet the higher goal), Make (positive and sufficient), and Some+ (positive in unknown degree). The corresponding negative types are Hurt, Break, and Some-. In Figure 5, there are two different contribution links pointing to the softgoal Reminders and alerts be sent regularly: a “Help” link and a “Some-” link. The two sub-tasks Only use current EMR system and Use new information system extending the EMR are two alternative means to achieve the end Patient information be managed. Therefore, the relationship between the two sub tasks is Or which means that the higher goal will be sufficiently met if any one of them is met. A simple reasoning on the contribution links indicates that the center should use a new information system for managing patient information. The new system should extend the current EMR for providing regular reminders and alerts to patients. With this in mind, we analyze the information needs for developing the new system.

For doing this, we focus on those members in the care team whose information needs are especially not met by the current EMR system. In addition to basic primary care, screening, and treatment services provide by the Nurse Practitioner, the center offers a constantly expanding range of chronic disease management, health promotion, and wellness services. The clinic houses a fitness center, teaching kitchen, and other common spaces for health promotion activities, such as yoga, line dancing, self-efficacy programs, creative arts therapy, smoking cessation, family fitness programs, and cooking classes. These facilities provide important information related to patients’ wellness. We identify several key roles in the care team who are the main information consumers and providers relying on the intended information system. Among them, Wellness Coordinator and

Behavioral Health Specialist are two key actors in the care team demanding an extension to the current EMR system. In this paper, we focus on modeling the information needs for these two key actors.

4.4.1 Wellness Coordinator

We begin with analyzing the intentional dependency relationships among actors. In the process of exploring the i* framework for modeling the social relationships among actors, we found that an ordinary i* SD model tends to describe as many dependency relationships among actors as possible. Consequently, an i* SD model is often cluttered without a focus. Our *second adaptation* is to use a *focal strategic dependency model* to describe the dependency relationships between a focal actor and a number of other actors.

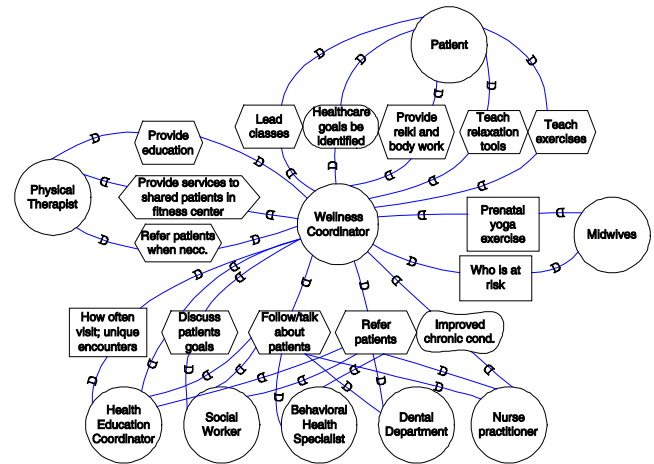

Figure 6: A Focal SD Model for Wellness Coordinator

Figure 6 shows a focal SD model describing the key relationships between Wellness Coordinator and a number of other intentional actors in the social context. Slightly different from normal i* SD models where any pair of actors would be connected as long as there are dependency relationships between them, a focal SD model looks like a snowflake where all the other actors only connect to Wellness Coordinator which is the focus of the graph. We use this type of SD model to describe the particular social context for a specific actor and avoid clutter in the diagrams.

Such a focal SD model will illustrate the intentional nature of the players in the surrounding environment. In addition, the following questions can be addressed systematically by modeling the dependency relationships between the focal actor and a set of other actors:

- Who are the major players interacting with Wellness Coordinator?
- What are the job responsibilities for Wellness Coordinator?
- What kinds of relationships exist among the players?
- What are the information needs in the responsibility and the dependency relationships?

Specifically, the Wellness Coordinator provides the services for several healthy living programs to patients. These programs include Provide reiki and body work, Teach relaxation

tools, and Teach exercises. In other relationships with patients, the Wellness Coordinator works with patients to identify healthcare goals and may ask some patients to Lead classes.

The Physical Therapist often shares patients with the Wellness Coordinator in the fitness center. They refer patients to each other when they see the needs. Moreover, the Physical Therapist relies on the Wellness Coordinator to provide wellness education for improving patients' knowledge about adopting more healthy living styles.

The Wellness Coordinator exchanges information with the Health Education Coordinator and the Social Worker about the goals of the patients in terms of illness management. The Health Education Coordinator depends on the Wellness Coordinator to track the visits of the patients to the fitness center and record any unique encounters during the visits. In a broader context, the Wellness Coordinator exchanges notes with the Behavioral Health Specialist, Dentist, and the Nurse Practitioner about patients' progresses, referrals, and health care objectives. These communications require a great volume of information flowing among these actors. Accurately capturing and efficiently accessing the relevant information in the system will be a key to the requirement.

We have found that the center also needs services provided by other contractors such as Podiatry and Midwifery. In particular, the Wellness Coordinator needs to exchange information with Midwives about the pregnant patients who are at risk when attending fitness classes. The Wellness Coordinator also offers prenatal yoga exercises which are recommended by Midwives to patient.

Finally, the Nurse Practitioner expects that patients would improve their chronic conditions through participating in the healthy living programs supervised by the Wellness Coordinator. This is represented by the softgoal dependency relationship Improved chronic conditions from the Nurse Practitioner to the Wellness Coordinator in the strategic dependency (SD) model in Figure 6.

4.4.2 Behavioral Health Specialist

A healthcare innovation at the center is the seamless integration of behavioral health services with primary care. This innovation is aimed to improve the effectiveness and efficiency of treatment, while reducing the stigma typically associated with specialty mental health services. In Figure 7, the behavioral health specialist models the key relationships between her and a number of other actors. We also can systematically explore the same set of questions using the focal SD model as for Wellness Coordinator. Specifically, we are able to discover the major players interacting with Behavioral Health Specialist, the job responsibilities of the behavioral health specialist, the kinds of relationships that exist among the players, and the information needs of the Behavioral Health Specialist when she carries out the responsibility and interacts with other players through the dependency relationships.

In particular, one of the major responsibilities for the Behavioral Health Specialist is to screen patients using a set of pre-defined templates. She exchanges patient information with a special player Nurse Family Partnership for shared

patients. The director of the center looks into the innovations at the center by collecting data from the behavioral health services and develops new health policy for certain groups of population. We notice that the behavioral health specialist relies on the receptionist at the front desk for managing several privacy and security issues related to patients' health information. One of issues is to hand out necessary information to patients at registration including HIPAA-compliant consent forms. Patient privacy and the security of patient health data is one of the highest concerns when designing a tracking system, especially, when dealing with behavioral health information.

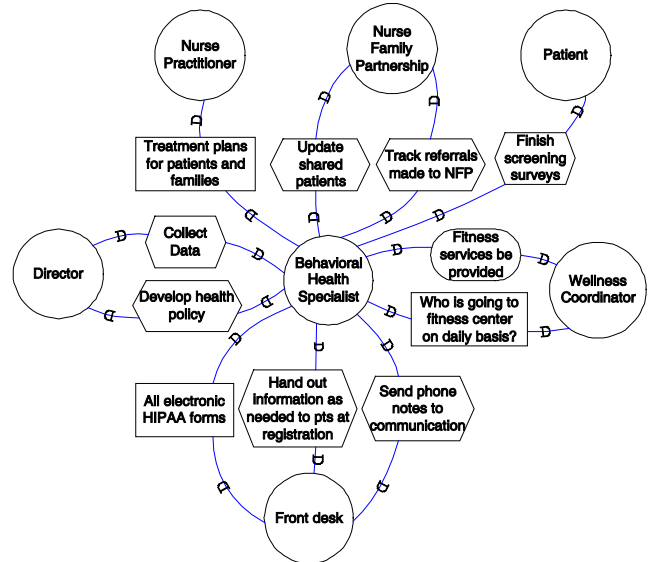

Figure 7: A Focal SD Model for Behavioral Health Specialist

The Behavioral Health Specialist will request information from the Wellness Coordinator for providing fitness services and the attendance at the fitness center. The behavioral health specialist will work with the Nurse Practitioner to provide treatment services for patients and families if the behavioral health specialist identifies any mental health issues that may affect patients' health status.

4.4.3 Introducing the System as an Intentional Actor

One of the benefits of using i* framework for early requirements analysis is that the strategic dependency model can be used to describe not only the intentional relationships among existing strategic actors, but also the intentional relationships when the intended system is introduced as a strategic actor in the social context of the application domain. This is especially important for designing software intensive systems such as healthcare information systems where a software system is embedded in the application domain to "fit the purpose". In modeling the socio-technical environment for the transdisciplinary care approach at the center, we indicated to the participants that they should treat the intended system as a player in their environment whenever they considered it was necessary to interact with the system for achieving a goal or performing a task.

Figure 8 provides a SD model showing the key dependency relationships between the Wellness Coordinator and the intended Tracking System. In such a SD model, actors depend on each other for achieving their goals. To tell apart the different

directions of the dependencies, we make the dependency symbol “D” in different sizes.

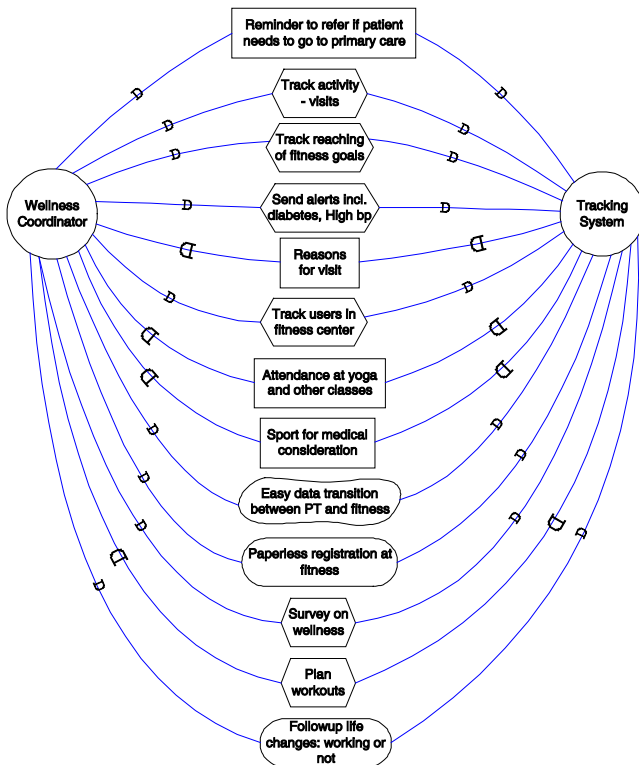

Figure 8: An SD Model between Wellness Coordinator and the System

As the Figure 8 shows, the wellness coordinator expects the system to provide reminders for writing referrals for patients who need to get primary care. This would be an automatic mechanism involving the development of intelligent algorithms. Related to this is to generate alerts about patients’ illness conditions and vital signs, e.g., high blood pressure. The system relies on the wellness coordinator to input the reasons for visit, record attendance at yoga and other classes, pick up sport for medical consideration, and plan workouts. The system will support the wellness coordinator to track patients’ activities in the fitness center, lifestyle changes, and patients’ feedback. Moreover, the wellness coordinator wants to have an easy data transition between her and the Physical Therapist. Finally, the intended system should help the wellness coordinator meet the goal Paperless registration at fitness center.

The SD model in Figure 9 describes the key relationships between the Behavioral Health Specialist and the Tracking System. Like the wellness coordinator, the behavioral health specialist also wants to receive alerts and reminders from the system. More specifically, the behavioral health specialist is concerned with patients’ behavioral health screening and children’s immunization. This requires searching for and using appropriate screening tools and templates in the system. Among other relationships, there are goals for keeping better track of children and supporting better educational handouts. The system relies on the behavioral health specialist to screen patients in terms of mental health issues. If there are needs for the services

from other providers, the behavioral health specialist writes referrals using the system.



Figure 9: An SD Model between Behavioral Health Specialist and the System

4.5 Strategic Goals Analysis

After modeling the intentional relationships among actors, we want to look inside each actor for a more detailed analysis of goals, tasks, and resources. The purpose of the detailed analysis is to reach the best design decisions to fulfill the aggregate top-level goals. This is done through a systematic process of goal decomposition and reasoning. The process also explores a space of design alternatives when there are different ways to achieve a goal or perform a task.

For developing the intended tracking system, the stakeholders at the center have agreed that they wanted more than a basic storage-and-retrieval system. Specifically, the system should provide evidence-based decision support and aggregate population data to their clinicians for managing diseases. For evidence-based decision support, we treat this as a separate development project worthy of special attention, and it is in our future research agenda. In this paper, we focus on meeting the goal of tracking patient information for improving patient health conditions. The results of the strategic goal analysis are a set of strategic rationale models. In particular, Figure 10 provides a strategic rationale model showing the goal analysis and reasoning results for the Wellness Coordinator. We can use such a model to systematically answer the following questions:

- What are the healthcare objectives and criteria of success for the actors?
- What are the alternative techniques or methods used in achieving the objectives?
- What are the essential sub processes and components to implement the alternatives?

As Figure 10 shows, two goals Patient information be tracked and Patient attend fitness classes regularly are

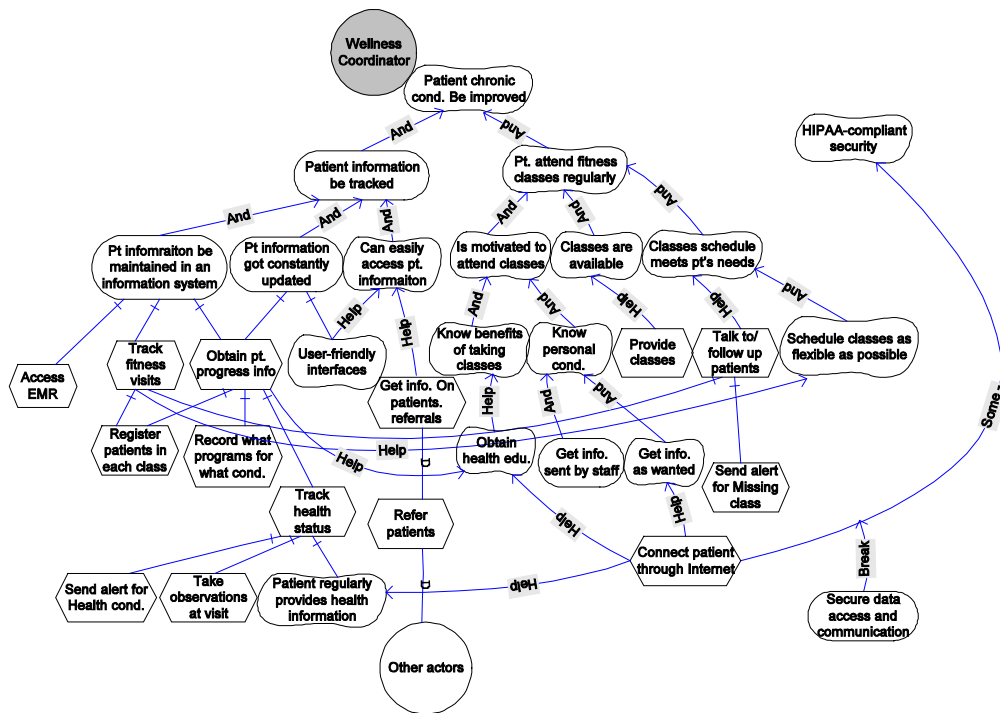

Figure 10: An SR Model for Wellness Coordinator

two sub-goals of the top softgoal Patient chronic conditions be improved for Wellness Coordinator. The goal Patient information be tracked is decomposed into three subgoals Patient information be maintained in an information system, Patient information got constantly updated, and Can easily access patient information. Continuing on decomposing and reasoning about the subgoals and tasks for meeting above three goals, we eventually identify the leaves in the hierarchy that can be operationalized to processes and mechanisms that are implementable. Specifically, the following list of tasks need to be performed for meeting the goal of keeping track of patient information: Access EMR, Register patients in each class, Record what programs for what conditions, Send alerts for health conditions, Take observations at visit, and Get information on patients referral. In addition, the user interfaces of the system should be user-friendly, and patients should regularly provide their health information through some ways.

On the other branch of the goal analysis in Figure 10, several goals and softgoals are identified in order to meet the goal Patient attend fitness classes regularly. In particular, patient should obtain health education in order to know the benefits of attending the classes, and get the information about their personal health conditions. One alternative for meeting these goals is to connect patients to the center through the Internet. Of course, there are some other alternatives for meeting these goals such as regular mail, phone communication, and home visit. For the sake of reducing the size of the diagram, these alternatives are not shown in the Figure. The alternative to using the Internet to connect patients contributes negatively (“Some-”) to the softgoal of maintaining HIPAA-compliant security.

However, developing secure data storage, access, and communication systems will break the negative contribution. For this reason, if we decide to design a Web-based patient portal, then data security will be one of the top priorities.

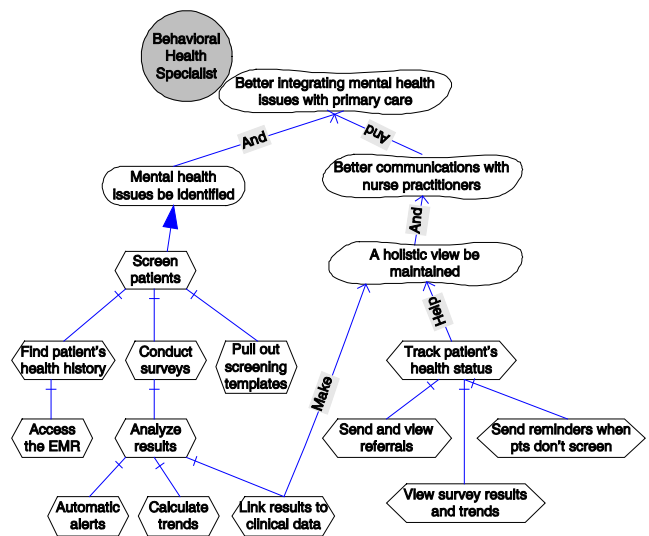

Figure 11: An SR Model for Behavioral Health Specialist

Figure 11 provides a strategic rationale model showing the goal analysis and reasoning results for Behavioral Health Specialist. The softgoal Better integrating mental health issues with primary care is and-decomposed into two subgoals: Mental health issues be identified and Better communications with nurse practitioners. The first goal is met by the task Screen patients, while the second

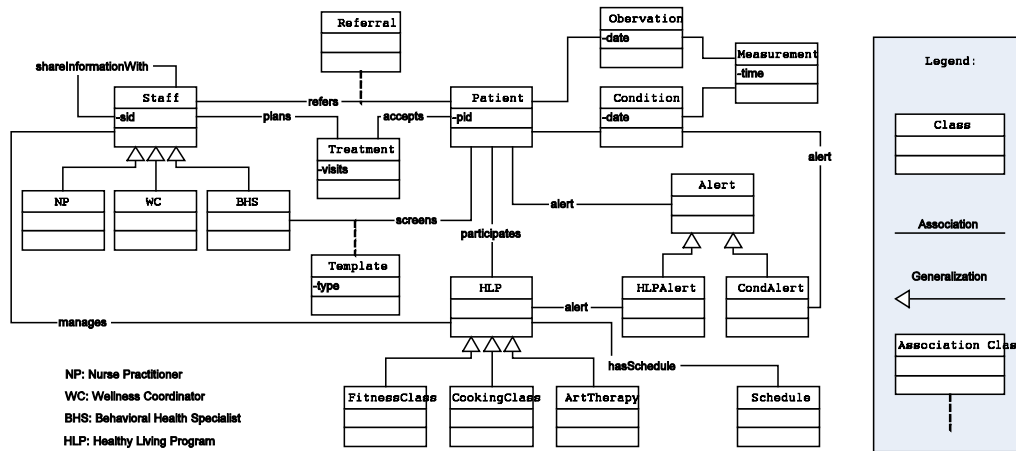

Figure 12: A Portion of a Software Model

softgoal is met by the sub-softgoal A holistic view be maintained. Continuing on goal analysis and reasoning, we identified a list of tasks that can be operationalized. These tasks are shown as the leaves in the tree (forest) structure of the goal model in Figure 11.

4.6 Requirements Specification

As we can see that early requirements analysis using the *i** approach generates a set of graphical goal models. The next step for requirements analysis is to capture and extract software requirements and create software models and specifications. In this paper, we use the UML class diagram to describe the software models for the intended PWT system.

A specification for software requirements contains the description of the operational environment for the intended system, external and internal interfaces, functional requirements including software models, and non-functional requirements. Although the extraction of requirements from graphical goal models is mainly a manual process involving a great deal of human judgment, several heuristics can be systematically applied here. In particular, the tasks identified in the SD and SR models mostly correspond to functional requirements of the intended system, while softgoals correspond to non-functional requirements. The intentional relationships captured in both SD and SR models provide relevant information for describing the operational environment including various constraints and for specifying external and internal interfaces.

Often, extracted requirements are accompanied by software models described in a modeling language such as UML. To produce software models from the goal models, we focus on the tasks that have been identified and can be operationalized. For example, in Figure 10, the task Register patients in each class has been identified and no further decomposition is needed. To operationalize the task, we would design a *FitnessClass* object in the system for storing the data fields related to a fitness class. With further exploration on the stakeholders' needs, we may identify a list of fields for the class including `class-number`, `instructor`, `exercise`, `location`, `begin-time`, `end-time`, `participants`, and `attendance`. The goal analysis increases the system designers' deep understanding of the design rationale. It may help

the designers in generating and gathering information for software design.

There have been several studies in the literature for proposing methodologies for systematically deriving software models from a goal-oriented analysis [10, 18]. In particular, a collection of terms called *domain notions* can be extracted from the models generated in the process of goal analysis. A term in a model is a domain notion if it describes a real-world concept, a relationship linking a concept, an attribute attached to a concept, or relationship in the domain. There are several heuristics that can be applied here: concepts usually correspond to noun phrases, attributes to possessive phrases and enumerations, and relationships to verb and prepositional phrases.

Figure 12 shows a UML class diagram describing a portion of the software model that is extracted from the strategic rationale model in Figure 10 as well as the other strategic dependency models involving the wellness coordinator. The diagram is only intended to illustrate the result of extracting software objects from goal analysis. For the sake of simplicity, we do not put the complete classes and the detailed information about class attributes in the diagram. With this type of model, detailed system design and implementation will follow as the next steps in the software development life cycle.

5. DISCUSSION

An information system is always embedded in the domain environment of a particular application, and often serves many stakeholders with different information needs. Designing an information system inevitably is a social activity [22]. Our preliminary experience on exploring the *i** framework for the requirements analysis in this case study showed that the *i** framework is a potentially effective tool for collaboratively modeling the socio-technical environment of healthcare information systems.

The *i** framework uses a set of visual notations for building the SD and SR models. In our first meeting with the staff at the center, we asked them to use simple circles and lines to draw simplified dependency graphs. In the next meeting, we used the full set of notations of the *i** framework for modeling the various intentional relationships in the social context. We gave only a 15-minute tutorial explaining what each symbol means.

Surprisingly, everyone understood the SD and SR models produced by the system analysts and started to make necessary modifications. The majority of the participants in our requirements analysis meetings have 20-37 years experience in health care and with Master's degree in Nursing. Most have used the EMR system for more than 1 year but have not received any formal training. They rated their computer savviness at a medium level. For validating the requirements, the stakeholders first checked the i* models, and then the system analysts validated the detailed requirements specification and software models by tracing back to the i* models. It increases the chance of capturing complete and accurate requirements.

The i* framework focuses on modeling the social and intentional dimensions for an application domain. It provides not only a tool for system analysts to model the requirements for intended system, but also a means for stakeholder to see the inter-relationships among the actors in the current environment. In particular, the transdisciplinary care approach has been described in the text by the center for administrative and communication purpose. However, the strategic dependency and rationale models describe the relationships among the staff in a more concise and vivid way. Participants in the meetings expressed the desire to look into the models in order to explore deep relationships in the health care approach.

Interactive and collaborative modeling is the key for system analysts to capture more complete requirements for an intended system. Our experience showed that the i* framework helped us for this interaction. For example, the center expressed their desire for a comprehensive healthcare information system to "link the healthy living programs to clinical data for better illness management." Our initial attempt during the first year was to identify the data items in the healthy living programs and design a database for collecting and analyzing the data. We only asked the "what" questions but did not delve into the "why" questions. Using the i* framework, we began to see a bigger picture in the center for patient health care. The collaborative social modeling approach breaks down both the terminology and technical barriers between system analysts and stakeholders. The project team has gained more confidence in designing and developing a system that could provide positive impacts and would be seamlessly integrated in the workflows of the stakeholders at the center.

However, our experience also showed several limitations of using the i* framework for eliciting and modeling requirements. First, it is not easy for a novice to express the intentional elements in terms of different categories such as goals, resources, tasks, and softgoals. Especially, goals are often expressed as tasks and vice versa. That was one of the reasons that we adopted a simplified dependency graph for the stakeholders to express their intentions. System analysts later refined them into different categories. Second, it is not easy to use i* models for expressing a sequence of activities. For example, a staff member wants to send a referral to other member and receive a response. The order of tasks cannot be expressed in i* models. Third, the formal goal refinement process is too time-consuming and technical-intensive for non-technical stakeholders. There lacks a systematic and effective way for eliciting refined goals to generate strategic rationale models. Stakeholders often expressed their goals and tasks in a list. System analysts had to arrange the elements in the list into a hierarchy and fill in intermediate steps.

6. RELATED WORK

Health information systems have demonstrated positive outcomes in improving care for chronically ill patients [13]. Bu et al. [6] show that information technology enabled diabetes management has the potential to improve care processes, delay diabetic complications and save healthcare dollar. Lee in [21] reports the nurses' experiences using health care information system. The study shows that there are many barriers for adopting information technology in nursing practices. In particular, nurses had problems with content design, insufficient training, were stressed by added work, experienced poor interdisciplinary cooperation. The study suggests that involving nurses early in the system design is the key to success.

It has been recognized that software requirements are located in the environment of the system to be built [17, 31], and requirements engineering and system design is a social activity [22]. Walker et al. [28] present a study on investigating user's requirements for a computer-based anatomy learning system. Callen et al. [7] introduce the contextual implementation model (CIM) for facilitating the implementation of clinical information systems. Damij examines the capability of a new object-oriented method called tabular application development in developing a hospital information systems [9]. However, none of these studies investigates the issue of how to effectively involve the stakeholders in the early stage of the system design.

The goal-oriented requirements engineering (GORE) approaches are concerned with the use of goals for eliciting, elaborating, and analyzing software requirements [19]. Current GORE approaches include KAOS [19], NFR [8], and i* [29]. Although GORE approaches have received an increasing attention recently in software requirements analysis, most of them do not deal with the social actor relationships that i* does. Specifically, the i* framework focuses on the intentional relationships among a set of strategic actors in an application domain. The i* framework has been applied to model the social context and surrounding environment for a number of issues including trust [30], security [14], and personal health records [26]. Our research in this paper focuses on exploring the i* framework for collaboratively modeling the requirements for an information system at a nurse-managed healthcare center.

7. CONCLUSION

We presented an analysis for the requirements of a patient wellness tracking system in a nurse-managed healthcare services center in an urban area. We have showed that the goal-oriented approach called the i* framework helped the system analysts and the stakeholders collaboratively elicit, analyze, specify, document, and reason about the requirements. Specifically, we have described that the patient wellness tracking information system is a complex socio-technical system that involved a number of different stakeholders. The collaborative social modeling using the i* framework provided a potentially effective approach for dealing the complexity through intentional relationships among strategic players/actors.

To thoroughly evaluate the effectiveness of the goal-oriented i* framework for eliciting the requirements from healthcare professionals, we plan to conduct more rigorous studies as proposed in Hevner's seminal paper [16] as well as in other design science research publications (i.e., [4]). We will conduct

both qualitative evaluation such as questionnaires for stakeholders' experience of using the i* framework, and quantitative evaluation such as the number and priority of requirements elicited. In addition, once the system is built, we will evaluate its impacts on the workflow of the staff and the outcomes of patient care. We will report our evaluation results and findings in future publications.

8. REFERENCES

- [1] Institute of Medicine. *Priority Areas for National Action: Transforming Healthcare Quality*. Washington, DC: National Academy Press, 2003.
- [2] Health Information Technology. Agency for Healthcare Research and Quality, 2008. <http://healthit.ahrq.gov>.
- [3] *Third International i* Workshop (istar'08), Recife, Pernambuco, Brazil*. <http://www.cin.ufpe.br/~istar08/site/>, 2008.
- [4] Richard Baskerville, Jan Pries-Heje, and John Venable, *Soft Design Science Research: Extending the Boundaries of Evaluation in Design Science Research*. DESRIST 2007, May 13-15 2007, Pasadena, CA, 2007: p. 18-38.
- [5] D. W. Bates, *Physicians and ambulatory electronic health records*. Health Affairs, 2005. **24**(5): p. 1180-1189.
- [6] Davis Bu, Eric Pan, and and others, *Benefits of Information Technology-Enabled Diabetes Management*. Diabetes Care, 2007. **30**: p. 1137-1142.
- [7] Joanne L. Callen, Jefferey Braithwaite, and Johanna I. Westbrook, *Contextual Implementation Model: A Framework for Assisting Clinical Information System Implementation*. Journal of the American Medical Informatics Association, 2008. **15**(2): p. 255-262.
- [8] L. Chung, et al., *Non-Functional Requirements in Software Engineering*. 2000: Kluwer Academic Publisher.
- [9] Talib Damij, *Development of a Hospital Information System Using the TAD Method*. Journal of the American Medical Informatics Association, 1997. **5**(2): p. 184-193.
- [10] A. Dardenne, A. van Lamsweerde, and S. Fickas, *Goal-Directed Requirements Acquisition*. Sci. Comput. Program., 1993. **20**(1-2): p. 3-50.
- [11] George Demiris, et al., *Patient-Centered Applications: Use of Information Technology to Promote Disease Management and Wellness: A White Paper by the AMIA Knowledge in Motion Working Group*. J Am Med Inform Assoc, 2007. **15**: p. 8-13.
- [12] EG Campbell DesRoches CM, K Donelan, et al. "..." N Engl J Med 359;1:50-60., *Electronic Health Records in Ambulatory Care – A National Survey of Physicians*. N Engl J. Med, 2008. **359**(1): p. 50-60.
- [13] David Dorr, et al., *Informatics Systems to Promote Improved Care for Chronic Illness: A Literature Review*. J Am Med Inform Assoc, 2007. **14**: p. 156-163.
- [14] Golnaz Elahi and Eric Yu, *A Goal Oriented Approach for Modeling and Analyzing Security Trade-Offs*. Proc. 26th International Conference on Conceptual Modeling (ER 2007), 2007: p. 375-390.
- [15] J. Finkelstein, G. O'Connor, and R. H. Friedmann, *Development and Implementation of the Home Asthma Telemonitoring (HAT) System to Facilitate Asthma Self-care*. MedInfo, 2001. **10**(Pt 1): p. 810-814.
- [16] A. R. Hevner, et al., *Design Science in Information Systems Research*. MIS Quarterly, 2004. **28**(1): p. 75-105.
- [17] Michael Jackson, *The Meaning of Requirements*. Annals of Software Engineering, 1997. **3**: p. 5-21.
- [18] Lei Jiang, et al. *Goal-Oriented Conceptual Database Design*. in *14th IEEE International Requirement Engineering Conference (RE'07)*. 2007.
- [19] A. van Lamsweerde, *Goal-Oriented Requirements Engineering: A Guided Tour*. In the Proceedings of 5th IEEE International Symposium on Requirements Engineering, 2001.
- [20] Mikyoung Lee, Connie Delaney, and Sue Moorhead, *Building a Personal Health Record from a Nursing Perspective*. International Journal of Medical Informatics, 2007. **76**(S): p. 308-316.
- [21] Ting Ting Lee, *Nurses' Experiences Using a Nursing Information System*. CIN: Computers, Informatics, Nursing, 2007. **25**(5): p. 294-300.
- [22] Lin Liu and Eric Yu, *Designing Information Systems in Social Context: A Goal and Scenario Modelling Approach*. Information Systems, 2004. **29**(2): p. 187-203.
- [23] John Mylopoulos, Lawrence Chung, and Eric Yu, *From object-oriented to goal-oriented requirements analysis*. Commun. ACM, 1999. **42**(1): p. 31--37.
- [24] Bashar Nuseibeh and Steve Easterbrook, *Requirements Engineering: A Roadmap*. In Proceedings of the Conference on The Future of Software Engineering (ICSE'00), 2000: p. 35--46.
- [25] Shari Lawrence Pfleeger and Joanne Atlee, *Software Engineering: Theory and Practice*. 2005: Pearson Prentice Hall
- [26] Reza Samavi and Thodoros Topaloglou, *Designing Privacy-Aware Personal Health Record Systems*. In the Proceedings of ER Workshops, LNCS 5232, 2008: p. 12-21.
- [27] Edward H. Wagner, *Chronic Disease Management: What Will It Take to Improve Care for Chronic Illness? Effective Clinical Practice*, 1998. **1**(1): p. 2-4.
- [28] Deborah S. Walker, et al., *Investigating User's Requirements: Computer-based Anatomy Learning Modules for Multiple User Test Beds*. Journal of the American Medical Informatics Association, 2002. **9**(4): p. 311-319.
- [29] Eric S. K. Yu, *Towards Modeling and Reasoning Support for Early-Phase Requirements Engineering*. In the Proceedings of the 3rd IEEE International Symposium on Requirements Engineering (RE'97), 1997.
- [30] Eric S. K. Yu and Lin Liu, *Modelling Trust for System Design Using the i* Strategic Actors Framework*. In the Proceedings of the workshop on Deception, Fraud, and Trust in Agent Societies held during the Autonomous Agents Conference, 2001: p. 175--194.
- [31] Pamela Zave and Michael Jackson, *Four Dark Corners of Requirements Engineering*. ACM Transaction on Software Engineering, 1997. **6**(1): p. 1-30.