

**Faculty of Arts and Science
University of Toronto**

Midterm Test

Department: Computer Science
Instructor: John Mylopoulos
Date and Time: 3:10pm, Monday February 26, 2001

Conditions: Closed book
Duration: 50 minutes

This test counts for 20% of your final grade

Name: _____

(Please underline last name)

Student Number: _____

Question Marks

1. _____/25

2. _____/20

3. _____/25

4. _____/30

Total _____/100

1. [Short Questions; 25 marks total]

(a) [Non-Functional Requirements – 5 marks] Describe two different ways of measuring the reliability of a software system.

Two of:

Uptime (System 100% operational) N% of the time (e.g., calendar year)

Mean-time-to-failure (MTTF) e.g., MTTF \geq 100hrs

No more than X bugs per YKLOC, e.g., \leq 10bugs per 10KLOC

(b) [Feasibility Study – 10 marks] Assume that a software development project costs \$20,000 to develop and \$2,000 to operate per year, but saves its owner \$10,000 per year. Do a payback analysis for 2 years past year 0 (when the system is developed), assuming an 11% discount rate.

	Year 0	Year 1	Year 2
Development costs	(\$20,000)		
Present value	(\$20,000)		
Operation costs		(\$2,000)	(\$2,000)
Present value		(\$1,800)	(\$1,620)
Savings		\$10,000	\$10,000
Present value		\$9,000	\$8,100
Net	(\$20,000)	(\$12,800)	(\$6,320)

1. [Short Questions; continued]

(c) [Use Case Diagrams – 10 marks] A midterm exam is prepared by the instructor and taken by each of the students in her class. In special cases, where the student misses the test, the student has to take a makeup test.

Draw a use case diagram for this situation.

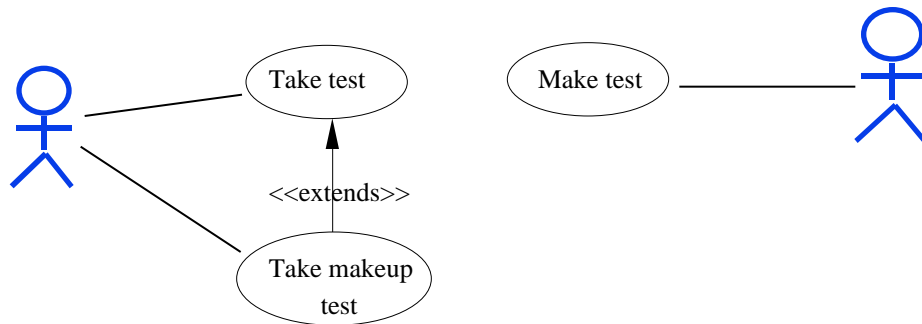

2. [Sequence Diagrams; 20 marks]

The College Street Red Cross Blood Donor Centre operates as follows: On the day of a blood donation, the Donation Unit receives blood donations from donors and sends them to the Testing Unit which tests each blood donation for blood type and potential viral agents. The Testing Unit then sends the blood donation along with test results to the Processing Office (another unit of the Centre) which fills a form for each tested blood unit where the tests are OK, and sends the blood units and forms to the Distribution Office. If tests indicate that a blood unit may be contaminated with a viral agent, the Processing Office destroys that unit.

Draw a sequence diagram for this scenario.

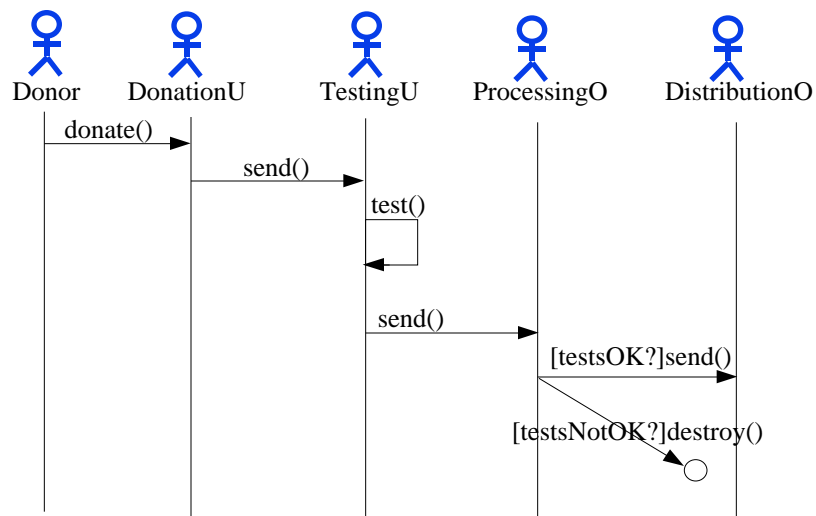

3. [State Diagrams; 25 marks]

The Distribution Office of the Blood Donor Centre distributes blood to various hospitals on request. Requests usually come in for specific amounts of specific blood types. The Distribution Office checks to see if it has the requested amounts for each blood type. If it does, the requested amounts for each blood type are packaged in a special container and sent to the hospitals through special hospital vans. If the Distribution Office doesn't have the requested amounts, it waits for another batch of blood donations to arrive. When a batch arrives, the Distribution Office checks to see if the hospital request can be fulfilled. If the request can be fulfilled (i.e., all requested amounts are available) then the requested amounts for each blood type are packaged and sent away, otherwise the Distribution Office waits for another batch of donated blood to arrive.

Draw a state diagram which describes how the Distribution Office fulfils hospital requests.

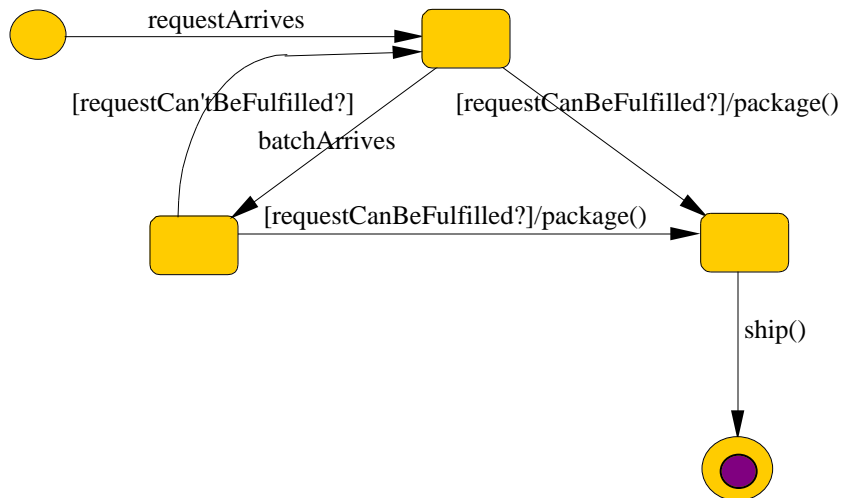

4. [Class Diagrams, 30 marks]

A university offers degrees to students. The university consists of faculties each of which consists of one or more departments. Each degree is administered by a single department. Each student is studying towards a single degree. Each degree requires one to 20 courses. A student enrolls in 1-5 courses (per term.) A course can be either graduate or undergraduate, but not both. Likewise, students are graduates or undergraduates but not both.

Draw a class diagrams which represents the generic objects and relationships described above. Make sure to specify multiplicities for all associations shown in your diagrams.

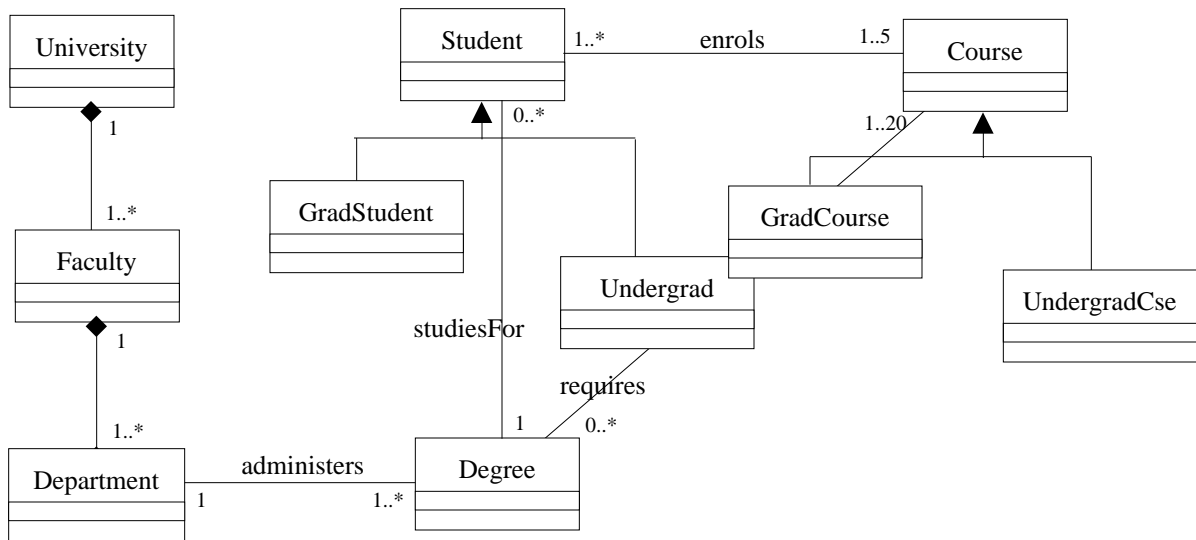

(Scratch paper)

(Scratch paper)